



HOBAS® GRP Pipe Systems

Transportation, Installation & Maintenance



Contents

1	Introduction	1
2	Transportation & Unloading of Pipes, Manholes, and Fittings	2
3	Storage	4
4	Installation	6
5	Mounting the Pipe Coupling	15
6	Manholes, Tanks, Fittings, and Special Structures	21
7	Pressure Pipelines	25
8	Leaktightness Testing of Gravity Pipelines	26
9	Testing of Pressure Pipelines	29
10	Cutting of Pipes On Site	31
11	Repair Work	32
12	Special Installation	33
13	Installation Inspection	35
14	Cleaning Pipelines	36
15	List of Relevant Standards, Design & Calculation Basis	37
	Appendix	40

1 Introduction

1.1 General Information

All data and recommendations contained in this manual or provided by HOBAS are general information about HOBAS GRP Pipe Systems and not binding for individual projects. Figures are schematic in nature and intended as examples only. They can differ according to the project or transport requirements. The information contained in the document is correct at the time of going to press. All data must be checked and revised as appropriate.

The correct installation of the pipes requires individual calculations and comprehensive planning by certified engineers. In addition to the applicable standards and guidelines, the requirements for each installation and the operating conditions for each project shall be evaluated by engineers. HOBAS does not generally verify the installation conditions on site, which hence is in the responsibility of the contractor or consulting engineer.

For the installation of HOBAS GRP Pipes, the relevant standards and guidelines such as EN 1610 and ISO/TS 10465-1 apply. HOBAS offers custom services based on individual advice. For special conditions requiring specific approaches, please do not hesitate to contact our HOBAS Technical Experts.

1.2 HOBAS Pipe Systems

HOBAS Pipes Systems are flexible pipe systems that deform under external loads within the scope of their design. The flexibility of HOBAS Pipes causes ideal load distribution on the surrounding bedding and soil, contrary to rigid pipes, which have to absorb the full external load. After the natural settling of the backfill material, the pipe/soil system stabilizes and the deflection stays constant.

1.3 Occupational Health and Safety

This installation manual does not replace codes of practice, applicable laws, safety, environmental or other regulations, local regulations, or specifications of the owner, planner, or building contractor who is the main authority in each project. From the delivery to the construction site to the commissioning of the pipe system, all legal and operational requirements with regard to occupational health and safety, fire protection and technical safety, must be observed independently of this installation manual. All instructions and figures must be checked individually prior to each application in accordance with the conditions on site. Particular attention shall be paid to the fact that the pipes have a very smooth inner and outer surface. With regard to moisture or materials such as oils, grease, etc. that are frequently found on construction sites, special caution is recommended when entering, storing, handling, and transporting the pipes.

2 Transportation & Unloading of Pipes, Manholes, and Fittings

In general, the legal provisions of the respective country's road traffic regulations apply to transportation. The pipeline components shall be delivered using suitable vehicles and have to be appropriately loaded and unloaded. Impact stresses shall be avoided. The packaging provided at the factory is adapted for the intended means of shipping, e.g. road, rail, or sea.

HOBAS Pipes and Fittings are loaded at the factories by trained personnel. Nevertheless, each delivery shall be checked for deficiencies upon arrival. Particular attention must be paid with regard to damaged pipe ends, strong abrasion and pressure marks. Any defects found shall immediately be noted in the corresponding freight and shipping documents in the presence of the freight forwarder so that they can be taken into consideration in the case of complaints. The damaged components must be labelled and stored separately. Pipe materials that have been processed due to in-house sampling or other reasons may look slightly different from unprocessed materials. This will however not be considered as grounds for complaint. In case of doubt, please contact HOBAS.

Please understand that subsequent complaints that could have been identified by proper inspection at the time of delivery can no longer be accepted. Interim transportation on the construction sites shall preferably be in the original packaging.

2.1 Pipe Transportation

The pipes are usually delivered in lengths of 6 m and with a pre-mounted coupling. To transport pipes with different diameters economically, smaller diameter pipes can be nested inside larger ones. The inserted pipes must rest on the surface below and must not be hung on steel belts. When unloading, the packaging units (Figure 1) must be lifted individually by means of slings.

To guarantee safe transport, single pipes shall be loaded and unloaded according to Figure 2. In certain cases it may be necessary to transport the pipes with the help of a cross beam inside the pipe. The beam shall be protected with mats (cushioning) accordingly to prevent mechanical damage to the pipes and couplings.

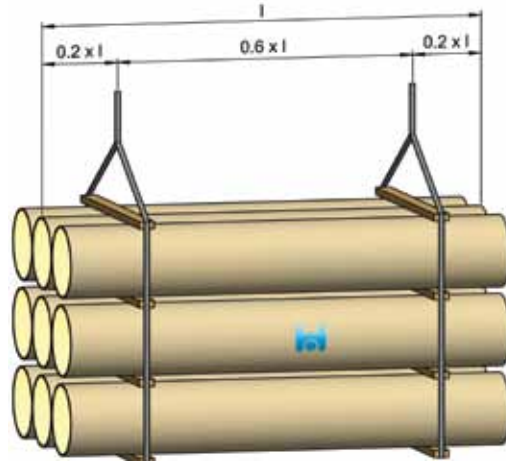

Fig. 1: Packaging units

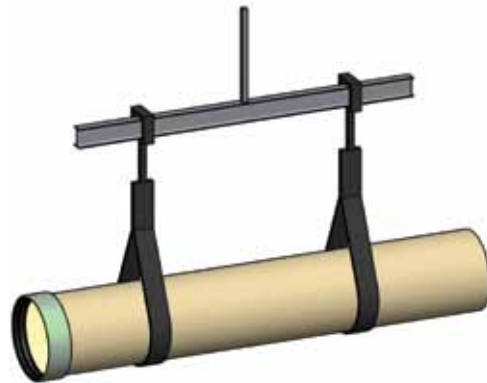

Fig. 2: Loading and unloading of pipes

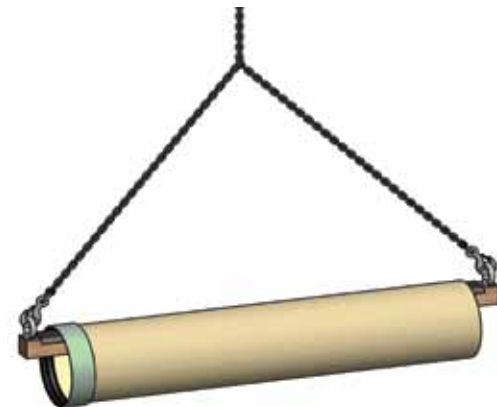

Fig. 3: Transportation with cross beam inside the pipe

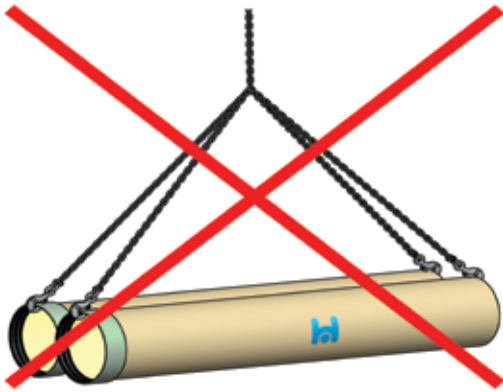

Fig. 4: Hooks and wire ropes must not be used for transportation

Avoid using hooks wire rope, chains, and hoisting gear with sharp edges. Do not subject the pipes to point loads (Figure 4). The pipes shall be denested with suitable devices which prevent the pipes from being damaged (Figure 5). Metal tools (forklift forks etc.) must be protected in such a way that pipe damage can be ruled out. The lifting slings for nested pipes must be removed immediately after the pipes have been unloaded (by cutting, not by ripping). Pulling the pipes across the ground or rolling them over longer distances (Figure 8) is prohibited.

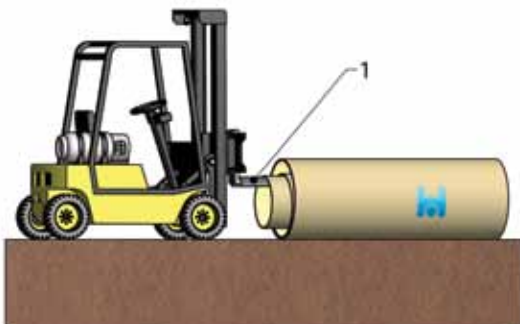

Fig. 5: One option for denesting the pipes

1 Rubber lining

2.2 Transportation of Manholes and Fittings

The same basic rules apply to the transportation of manholes and fittings. Manholes should be transported vertically or horizontally, depending on their design height. Loose accessories (e.g. cover plates) are mounted on site. Unloading shall take place with the help of lifting devices, e.g. anchors that are integrated in the wall of the manhole and to which ropes can be attached (Figure 6).

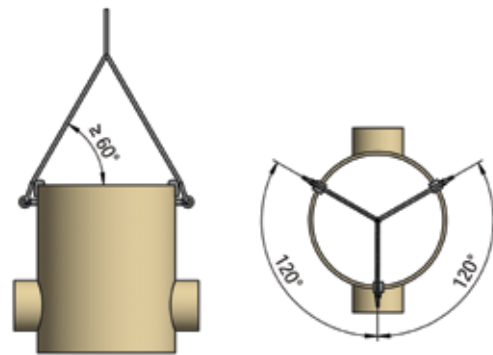

Fig. 6: Lifting aids for manhole transportation

Safety instructions

- All lifting aids must be used during transportation in order to avoid uneven load distribution
- The lifting devices (e.g. bolts, screws, etc.) must be checked prior to each use
- Damaged lifting aids must not be used
- Subsequent adaptation of lifting aids (e.g. cutting, grinding, bending, etc.) is prohibited

Impact and bending stresses must be avoided in the loading of both pipes and special structures.

3 Storage

The original packaging, mostly on pallets, is suitable for both transportation and storage. The pipes shall be stored on an even surface (Figure 7). The materials must not be subject to intense heat, flames, solvents, etc. Pipes must be protected from mechanical damage, contamination of the sealing gaskets, and point loads (Figure 8).

On temporary storage sites, pipes must be protected against vandalism and access by third parties, e.g. playing children. When stored alongside the pipeline route, pipes must be protected against damage and displacement. If pipes are subsequently stacked, the stacking height depends on the soil conditions as well as the loading and safety equipment on site (see Table 1).

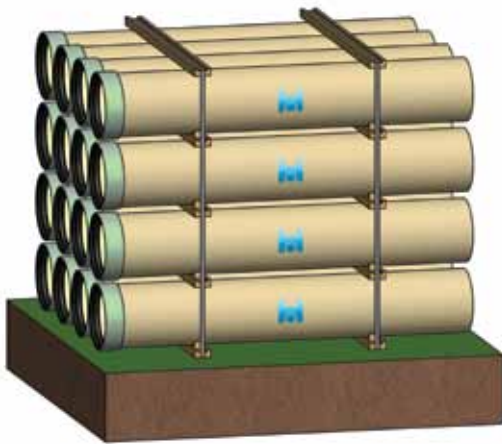

Fig. 7: Packaging unit

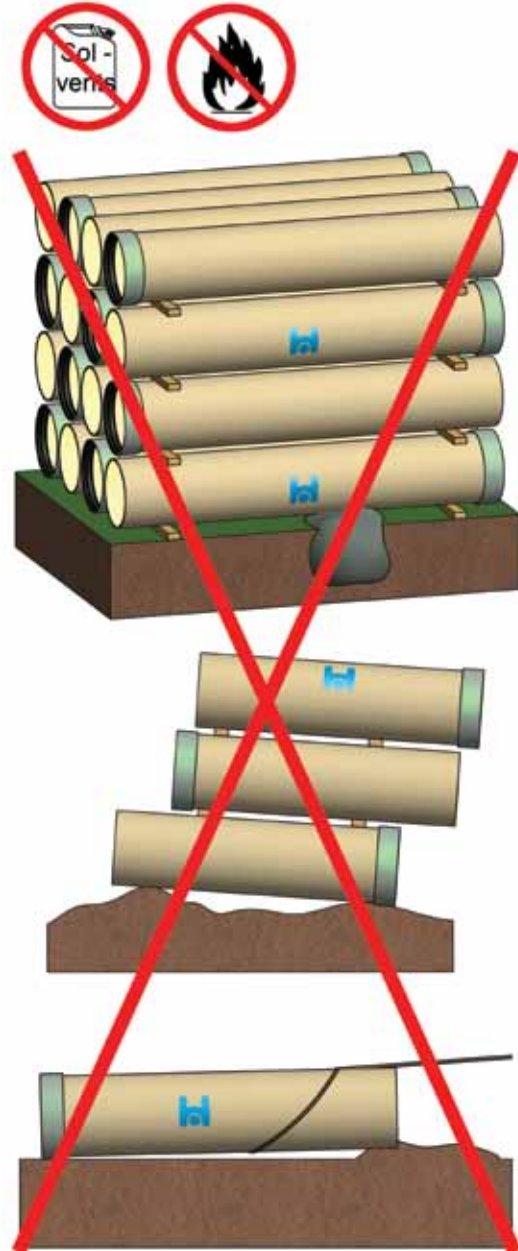

Fig. 8: Improper storage and handling of GRP pipes

Nominal diameter DN	150	200	250	300	400	500	600	700	800	900	1000	1100	1200	≥1400
Quantity	8	8	7	6	5	4	3	3	2	2	2	2	2	1

Table 1: Number of pipe layers relative to DN

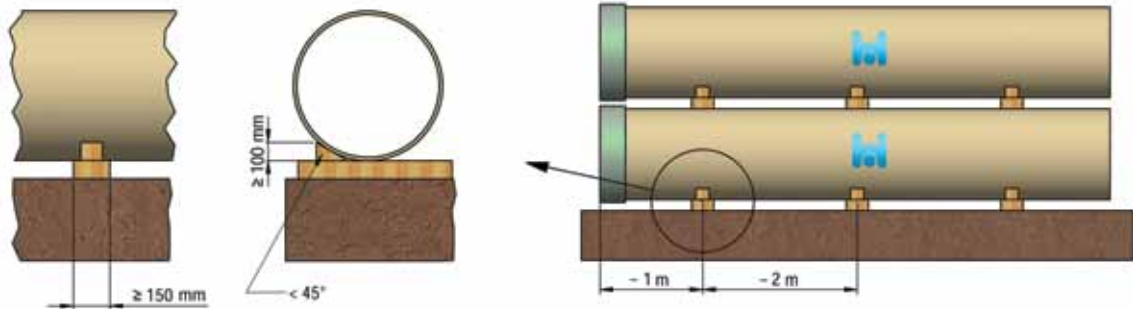

Fig. 9: Storage of pipes on wooden supports

Wooden beams must be placed under the bottom layer of pipes to avoid siltation due to rainwater draining and prevent the pipes from freezing. Stacking heights above 3 m are prohibited on construction sites to prevent accidents. The pipes must be secured in position with the help of wooden beams and wedges. HOBAS Pipes are usually supplied with a coupling mounted on one pipe end.

The inner pipe surface and rubber seals on the couplings must not be subject to UV light for more than 8 weeks. Furthermore, they must be protected from greases, oils, solvents, and other damaging substances. It is therefore advisable to cover the pipe ends if they are stored outdoors over a longer period (8 weeks).

4 Installation

A pipeline is an engineered structure where the interaction between the pipes, joints, supports, embedment, backfill, and cover form the basis for its ultimate stability and reliability. The pipe stiffness and soil consistency together determine system performance, a significant factor in buried installations. It is therefore the quality of the materials used and execution that are the most important criteria for the integrity of the finished pipeline structure.

4.1 Underground Installation

4.1.1 Pipe Trench

When selecting the pipe route, ensure that the line is as straight as possible because any changes in direction can have an adverse effects on hydraulic friction loss. Avoid counter slopes. If there are any, ports must be provided for venting at all the highest elevations and draining at the lowest elevations in the pipeline.

When designing and excavating pipe trenches and pits, we recommend complying with EN 1610. In addition, the requirements of ISO/TS 10465-1 can also be taken into consideration. It is generally the designer’s responsibility to meet specifications and follow local guidelines. Conditions on site should also be observed. It is important is to select the trench width allowing at least the required compaction to be achieved with suitable machinery and installation to be carried out safely and correctly (Table 2).

Excavated material that cannot be used for embedment in the trench must be separated from suitable backfilling material. If you have any questions about minimum or maximum depth of cover and special installation conditions, HOBAS will be happy to advise you. HOBAS can also provide structural calculations acc. to ATV-DVWK-A 127 if required.

Multiple pipelines

If planning multiple pipelines, also proceed as described in Section 4.1.1 and base calculations for the distance between them on the pipe with the largest diameter. It is important to always have enough space for proper compaction between the pipelines. The minimum spacing (x) between the pipelines should be 15 cm. If you need to walk along the trench during the installation, leave at least 50 cm between the pipes for bedding work (Figure 10). Proceed in a similar way for stepped trenches, as the lower trench area is usually backfilled first.

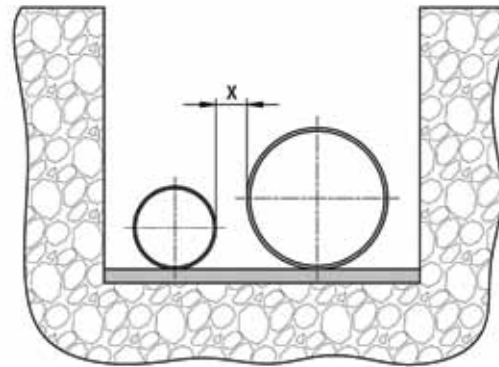

Fig. 10: Minimum spacing (x) between pipelines

Diameter (mm)	Minimum trench width ($D_e + x$)		Trench depth		
	Lined trench (m)	Unlined trench		Trench depth (m)	Minimum trench width (m)
		$\beta > 60^\circ$	$\beta \leq 60^\circ$		
≤ 200	$D_e + 0.40$	$D_e + 0.40$		≤ 1.00	not specified
> 200 to ≤ 350	$D_e + 0.50$	$D_e + 0.50$	$D_e + 0.40$	> 1.00 to $\leq 1,75$	0.80
> 350 to ≤ 700	$D_e + 0.70$	$D_e + 0.70$	$D_e + 0.40$	> 1.75 to ≤ 4.00	0.90
> 700 to ≤ 1200	$D_e + 0.85$	$D_e + 0.85$	$D_e + 0.40$	> 4.00	1.00
> 1200	$D_e + 1.00$	$D_e + 1.00$	$D_e + 0.40$		

Table 2: Minimum trench width

Installation with steep gradients

Where pipe routes have steep gradients, e.g. on slopes or mountains, you need to prevent the pipeline from sliding down and the bedding material from being washed out. In most cases this can be achieved with concrete slabs, which stop both the bedding layer from being washed away and the pipeline from being undercut. The planer has to design the concrete slabs accordingly to secure the pipeline in the longitudinal direction.

Keep the trench dry while laying the pipes. Also ensure that surface water drains away from the trench. For steep gradient pipelines, suitable means of compacting the bedding material must be available to ensure a proper installation.

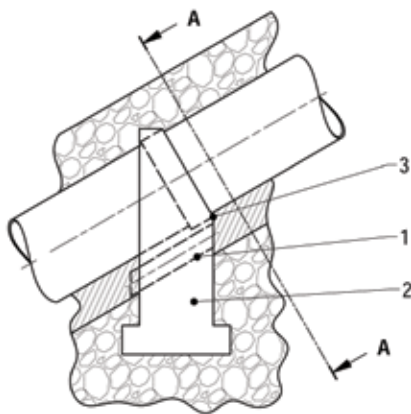

Fig. 11: Sideview of a support in steep terrain

- 1 Drainage pipe
- 2 Concrete support
- 3 Concrete support has to be flush with the coupling

4.1.2 Soil Types

Both the native soil and the bedding material have to be of adequate load-bearing capacity. Do not use any frozen soil in the pipeline zone or backfill on top of frozen bedding. HOBAS Pipes are also ideal for many difficult soil conditions because of their outstanding properties. Given their low weight, they are particularly suitable for soils susceptible to subsidence. It may still prove necessary to take special action with soils prone to settling or of inadequate load-bearing capacity in order to prevent the pipe from sinking. There is a risk of subsidence in particular in peaty or clayey soils, etc. We recommend the exchange of soil or using geotextiles, gravel beds, duckboards, etc. It depends on the designer's foundation recommendations based on the soil investigation report.

Laying pipes in groundwater

To guarantee a safe structure in the long term, the soil and groundwater conditions must be examined. Installation in groundwater requires special consideration. Where pipelines lie in groundwater, check that flotation is prevented and take appropriate action if necessary.

Take appropriate steps to ensure that the trench stability meets the project specifications and complies with safety requirements, e.g. with sheeting. It is important for shoring system installation and removal to be taken into account in the structural calculations. When removing the sheeting or shoring, the pipeline must not be damaged or its location changed.

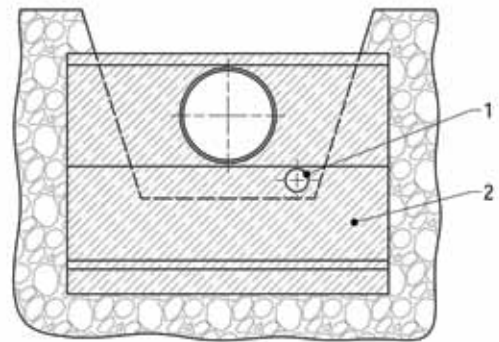

Fig. 12: Front view (section A-A) of a support in steep terrain

Soil types (to ATV 127)	Modulus of deformation ES (N/mm ²) and degree of compaction D _{pr} (%)					
	D _{pr} = 85	90	92	95	97	100
Group 1: Non cohesive soils (e.g. gravel)	2	6	9	16	23	40
Group 2: Slightly cohesive soils (e.g. sand)	1.2	3	4	8	11	20
Group 3: Cohesive mixed soils (sand/clay mixtures)	0.8	2	3	5	8	14
Group 4: Cohesive soils (e.g. clay)	0.6	1.5	2	4	6	10

Table 3: Modulus of deformation and degree of compaction

4.1.3 Trench Bottom and Pipe Bedding

Load-bearing pipe bedding is an important requirement for a long-lasting pipeline that functions properly. Prepare the trench bottom for the specified gradient and depth of installation. Avoid any loosening of the soil in the area of the bottom here (Table 3).

If it has however become loosened, place suitable bedding material in the trench bottom to equalize load distribution, and tamp it evenly to the original density or the minimum compaction indicated in the structural calculations. When the native soil consists of clay or silt, it sometimes proves necessary to lay a drain for dewatering and ensure the pipe bedding is dimensioned as described below. First place the pipe bedding on the excavated trench bottom. When compacted, it must be of at least the following thickness:
 Bedding: $0.1 \times \text{DN}$ or at least 15 cm (Figure 13). If the soil is soft or not load bearing, replace another 15 cm with soils of groups 1 or 2.

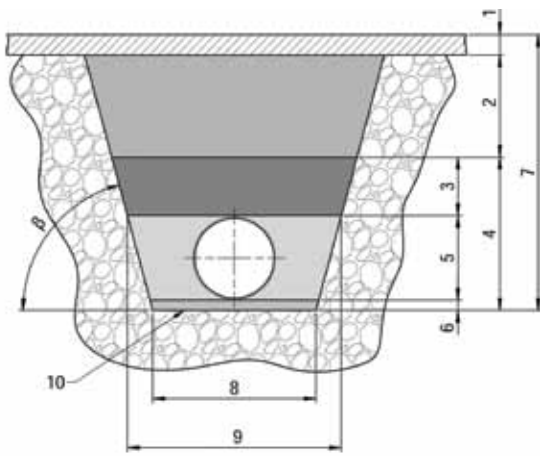

Fig. 13: Pipe trench to ATV-DVWK-A 127

- | | |
|--------------------|------------------------------|
| 1 Surface | 6 Bedding |
| 2 Final backfill | 7 Trench depth |
| 3 Cover | 8 Trench width at bottom |
| 4 Pipeline zone | 9 Trench width at pipe crown |
| 5 Initial backfill | 10 Trench bottom |
| | α Trench wall angle |

To ensure that the pipe barrels lie smoothly and evenly on the bedding, leave suitable bell holes in the area of the coupling (about 2–3 times the coupling width). When making the hollows for the couplings in the pipe bed, ensure there is room for joining the pipes and checking them, and no pressure peaks due to bad bedding can act (Figure 15).

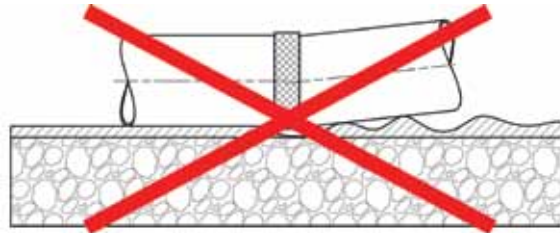

Fig. 14: Improper pipe bedding

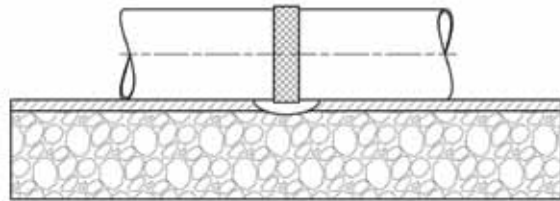

Fig. 15: Pipe laying with bell hole

4.1.4 Placing in the Pipe Trench

Before lowering the pipe into the trench, again inspect all parts to be installed for damage. Depending on the weight and local conditions, the installation parts, especially the pipes, can be placed by hand. If used, lifting or suspension gear should not pose any risks of damaging the material. Hooks, chains, wire rope, and other sharp-edged equipment that could slip and cause impact or shock should be avoided at all costs. It is therefore advisable to use at least two textile slings per 6 meter pipe. Pay particular attention to preventing the pipe from slipping in the slings (ensuring health and safety at work)

4.1.5 Embedding in the Pipeline Zone

Embed the pipeline immediately after lowering the pipes into the trench and joining them. A good quality of embedding in the area of the pipe zone is essential to provide support and primarily determines the pipeline's load-bearing capacity. Incorrect embedment can cause excessive pipe deflection.

The initial backfill therefore has to be compacted properly using suitable machinery (e.g. hand tamper or small pneumatic compactor). When using compacting machines, ensure that the pipes are not damaged during the process. Proceed with due care, especially if pipes of smaller diameters have thin walls. Place the bedding material on both sides of the pipeline from a diameter of DN 400 up to a depth of max. 30 cm above the crown in layers of 30 cm maximum and then compact them. If the diameters are smaller, adjust the layer depth accordingly to 100 to 200 mm.

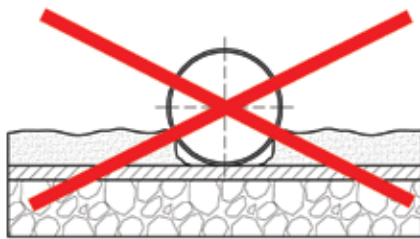

Fig. 16: Inadequate backfilling at the haunches

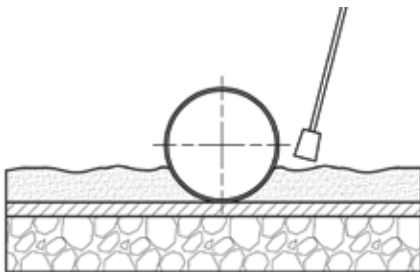

Fig. 17: Proper backfilling at the haunches

Pay particular attention to compacting the backfill under the pipe haunches (Figure 17). Compact the material less above the crown area if necessary to prevent pipe deflection (horizontal ellipse). The degree of compaction at the side of the pipes inside the pipeline zone should be at least $D_{pr} = 90\%$ or as determined by structural calculations. The initial deflection must be checked.

When the backfill has reached the pipe crown, vertical ovalization should not exceed 1.5 % of the pipe diameter (vertical ellipse). Horizontal deflection (horizontal ellipse) should be avoided where possible.

If necessary, backfilling and compacting should therefore be carried out on both sides at the same time or the pipeline weighed down in sections with bedding material. In the area of the embedment zone, compact manually or use light vibrating tampers (max. impact force 0.3 kN) or light plate compactors (max. impact force 1 kN) with appropriate compaction depth.

To achieve the necessary compaction, keep the pipe trench free of water. Compaction work during installation must not cause the direction or height of the pipeline to be altered. Pay particular attention to this where the pipes are light. Dewatering serves to create the required conditions for ensuring installation complies with regulations. When it rains, steps also have to be taken to prevent fines from being washed out. Work involved in installing and removing dewatering systems must be carried out in such a way that the stability of the environment and pipeline is not adversely affected. Structural analysis is required accordingly for any special work. Only use G1 or G2 soils to ATV-DVWK-A 127 capable of being compacted for embedment, apart from where exceptions apply. If the soil is saturated with groundwater or water bearing, material without fines must be used for embedding and backfilling. Use material of the following grain sizes that is capable of being properly compacted (Table 4).

Requirements for bedding material	
Soil group:	G1, G2
Grain size:	≤ 16 mm for pipes ≤ DN 400 ≤ 32 mm for pipes > DN 400

Table 4: Requirements for bedding material

Take appropriate action to prevent bedding material from migrating into or mixing with the native soil, e.g. use geotextile separation fabrics. Ensure that the density of the soil in the pipeline zone required in the structural calculations is achieved with appropriate compaction. Make absolutely sure that the compaction in the embedment zone is at least of the same level as that of the pipe cover. If you work with sheeting or shoring, remove it in layers and compact the bedding material against the trench wall layer by layer. This prevents higher loads on the pipe or it from being displaced. In every case the type of trench lining and removal selected must conform to the structural calculations.

4.1.6 Final Backfilling of the Pipe Trench

After the embedment zone comes the cover. In addition to EN 1610, we also recommend following the DWA A 139 code and taking the national rules and regulations into consideration for backfilling. Fill the trench and cover the pipe in layers of such depths that on one hand the pipeline’s stability is not at risk and on the other the soil can be adequately compacted. From 0.3 to 1.0 m crown cover (Zone B in Figure 18) you can compact the soil with medium vibrating tampers (max. impact force 0.6 kN) or plate compactors (max. impact force 5 kN). Medium and heavy vibrating rammers and compactors may only be used from a cover of 1 m (Zone A in Figure 18). Compacting the soil above the pipeline by dropping heavy weights or pressing it with excavator buckets is not permissible. Comply with the specifications in DWA A 139 (Table 5) or national regulations.

The maximum deflection after final backfilling of the pipe trench must also meet the designer’s specifications. We recommended using the ATV-DVWK-A 127 standard for structural analysis. According to ATV-DVWK-A 127, the permissible long-term vertical deflection must not exceed 6 %. Special loads occurring during installation from heavy machinery or construction vehicles, which do not reflect the structural conditions when pipeline installation is complete, must be verified with separate structural calculations. Additional effects such as vacuum must also be taken into account.

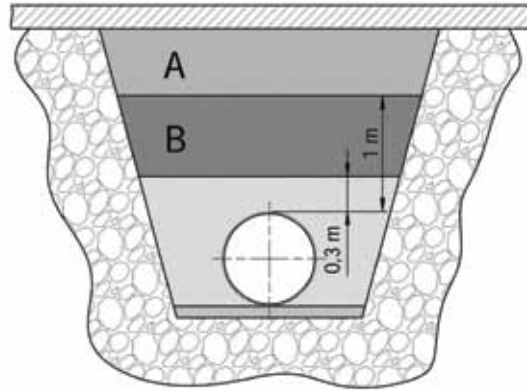

Fig. 18: Zones for using compaction equipment

- A Use of medium and heavy vibrating rammers and compactors (max. 80 kN)
- B Use of vibrating tampers (max. impact force 0.6 kN) or plate compactors (max. impact force 5 kN)

Type of machine		Service weight (kg)	Compactibility classes								
			V1*			V2*			V3*		
			Suitability	Fill depth (cm)	Number of transitions	Suitability	Fill depth (cm)	Number of transitions	Suitability	Fill depth (cm)	Number of transitions
1. Compacting machines (primarily for pipeline zone)											
Vibrating tamper	light	to 30	+	to 20	2-4	+	to 20	2-4	-	-	-
	medium	30-60	o	20-40	2-4	o	20-30	3-4	-	-	-
	heavy	60-100	o	30-50	2-4	o	20-40	3-4	-	-	-
Rammer	medium	to 100	o	20-40	3-4	o	20-40	3-4	-	-	-
Plate compactor	light	to 100	+	bis 20	3-5	+	bis 15	4-6	-	-	-
	medium	100-300	o	20-30	3-5	o	15-25	4-6	-	-	-
2. Compacting machines (above the pipeline zone from 1 m cover depth)											
Vibrating tamper	medium	30-60	+	20-40	2-4	+	20-30	2-4	o	10-30	2-4
	heavy	60-100	+	30-50	2-4	+	20-40	2-4	o	20-30	2-4
Rammer	medium	to 100	o	20-40	3-4	o	20-40	3-4	o	20-30	3-5
Plate compactor	medium	100-300	+	20-40	3-5	o	20-40	3-5	-	-	-
	heavy	300-750	+	30-60	3-5	o	30-50	3-5	-	-	-
Vibrating roller	heavy	600-8000	+	30-80	4-6	+	30-60	4-6	o	30-60	4-6

Table 5: Soil compaction, fill depths, and number of transitions to DWA A 139

+ Recommended

o Generally suitable, check in each individual case

- Unsuitable

* V1 Non cohesive to slightly cohesive, coarse and mixed grain soils (GW, GI, GE, SW, SI, SE, GU, GT, SU, ST)

V2 Cohesive, mixed grain soils (GU, GT, SU, ST)

V3 Cohesive, fine grain soils (UL, UM, TL, TM)

4.1.7 Laying in Liquid Soil

Pipe laying in liquid soil requires thorough preparation. Note in particular:

- Planning requirements
- Structural analysis
- Selection of the liquid soil or the recipe to achieve the required properties
- Selection of the shoring technology
- Any existing lines, cables, etc. crossing the route
- Groundwater table
- Securing the pipeline's location, in particular to prevent flotation
- Quality assurance plan for the entire installation process

In particular, determine the correct stiffness class at the design stage. Depending on the installation technology to be used, pipes deviating from the standard length may prove necessary. When preventing pipeline flotation, ensure that it does not lead to any deflection, displacement, or damage. Sheeting or shoring must be installed in such a way that the liquid soil fills all the cavities and the structural analysis conditions are met. Given the wide range of conditions and factors involved, we recommend consulting an experienced designer at the preliminary planning stage. HOBAS works together with experienced experts and is happy to help.

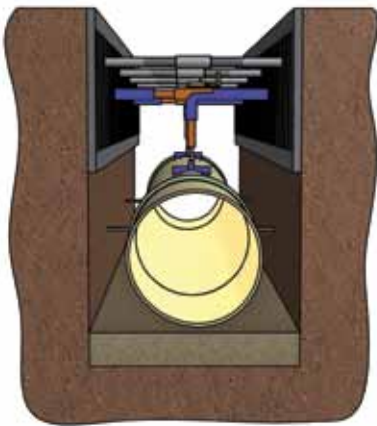

Fig. 19: Possible flotation restraints for installation in liquid soils, front view

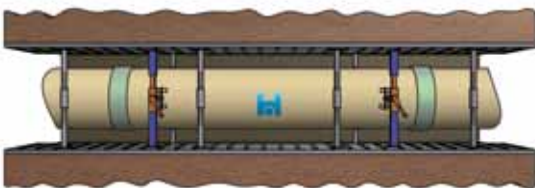

Fig. 20: Possible flotation restraints for installation in liquid soils, top view

4.2 Above-Ground Installation

This section describes the above-ground installation of pipelines with HOBAS Standard Couplings.

Support spacing

If a standard pipe with a length of 6 m is used, the supports may be located at 3 m or 6 m intervals depending on the diameter (Figure 21, Figure 22, Figure 23). When determining the support spacing and design, you also have to take external effects, such as wind, snow or other loads into consideration.

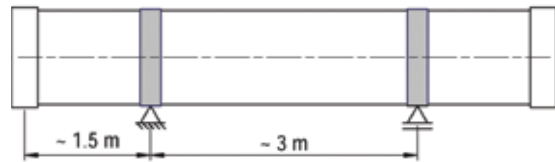

Fig. 21: Support spacing for gravity pipelines, DN 150–3600

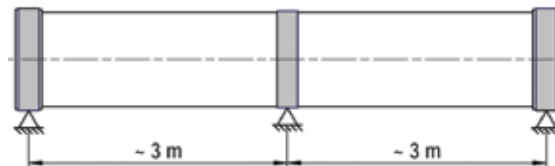

Fig. 22: Support spacing for pressure and gravity pipelines, DN 150–500

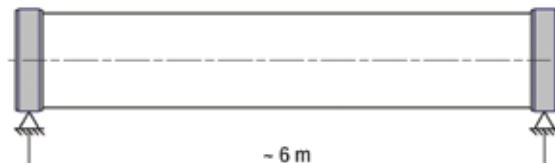

Fig. 23: Support spacing for pressure and gravity pipelines, DN 600–3600

To ensure that temperature-related expansions in every pipe can be compensated in the next coupling, secure every second support in place with a tightly done up clamp. This only applies if all the supports are attached to the pipe. If the supports rest on the coupling itself, tighten all the clamps securely.

Support design

When designing the supports and other means of restraining the pipes, take the longitudinal and lateral forces acting on the pipeline into account. This applies in particular to pressure pipes and pipelines subject to more extreme differences in temperatures. It is the designer's and customer's responsibility to ensure that the supports comply with the project specifications. Local load points should be prevented and the supports therefore designed accordingly. The supports must be designed to withstand loads that are caused by:

- The weight of the pipe and medium
- External loads (wind, snow, etc.)
- Shear forces caused by internal pressure (in pressure pipes)
- Forces caused by friction on the supports due to temperature and/or pressure fluctuations

Friction forces in the supports are the result of contraction and expansion of the pipe during operation (internal pressure, temperature) and friction resistance in the joint with a rubber support. Different support systems are possible, e.g. for suspended pipelines (bridge drainage, etc.).

The width of the support should be 200 mm and the support angle at least 120°. Elastic bedding approximately 5 mm thick (shore hardness: 45–50, made of EPDM, no PVC plasticizer) is required between the pipe and support material to prevent point loading.

The pipe clamp should be rounded on the inside edges and its inside diameter plus rubber support about 0.5 % larger than the outside diameter of the pipe or coupling.

Support types

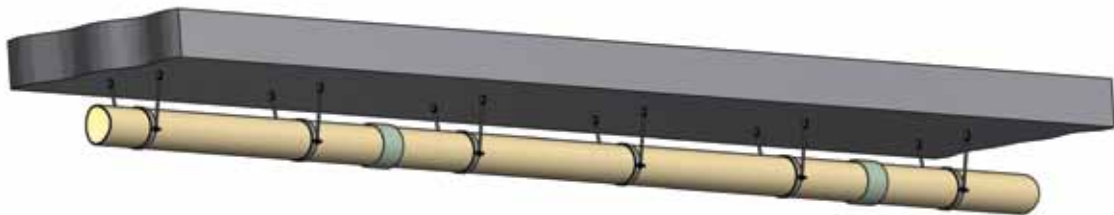

Fig. 24: Suspended support, e.g. bridge drainage

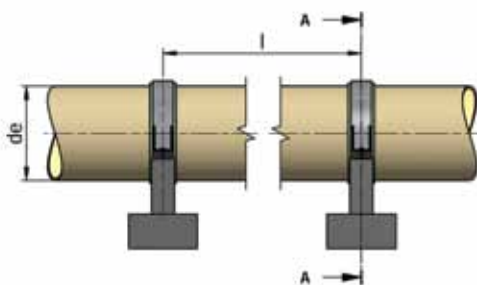

Fig. 25: Above-ground support at the coupling

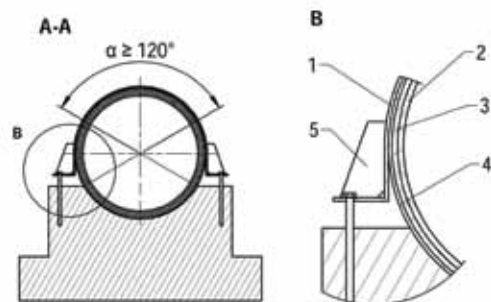

Fig. 27: Above-ground support at the coupling, cross-section

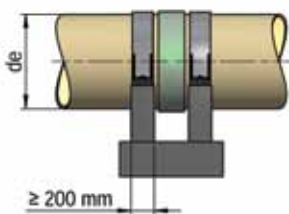

Fig. 26: Above-ground support at the pipe

- 1 Support
- 2 Pipe
- 3 Coupling
- 4 Rubber belts
- 5 Clamp
- α Supporting angle
- de Outside diameter

Temperature effects

The prevailing temperature conditions can vary considerably between above-ground and buried pipelines. If a pipeline is empty, e.g. during installation, there is a greater tendency for it to heat up, above all when exposed to sunlight. A medium flowing in it however normally compensates for changes in temperature. When calculating the change in length due to temperature fluctuations, use a thermal expansion coefficient α of approx. $30 \times 10^{-6} 1/^\circ\text{K}$ in the longitudinal direction.

$$s = (T_{\text{max}} - T_{\text{inst}}) * l * 30 * 10^{-6} \tag{1}$$

- s Change in length [mm]
- T_{max} Max. pipe temperature due to environment or medium [$^\circ\text{C}$]
- T_{inst} Pipe temperature during installation [$^\circ\text{C}$]
- l Pipe length [mm]

Temperature difference in medium or environment (K)	Temperature expansion in 6 m pipes (mm)
20	3.6
30	5.4
40	7.2
50	9.0
60	10.8

Table 6: Changes in length of 6 m pipes as a function of temperature difference

HOBAS Standard Couplings generally absorb any changes in length due to temperature differences, with the result that in such cases there is no need for special expansion joints. For applications with higher medium temperatures, contact HOBAS. HOBAS Pipes can be used with medium temperatures of up to 80°C .

Environmental effects on the outside of the pipe (UV light, weather)

The outer layer of the pipes protects the structural layers below from environmental impacts, such as ultraviolet radiation and the weather. This is achieved with a particularly compact layer of sand matrix composite. In regions subject to higher ultraviolet light exposure, the outer layer can also be adapted to be even more resistant to ultraviolet radiation.

5 Mounting the Pipe Coupling

Various coupling systems are available for HOBAS Pipes. HOBAS will be happy to help you determine the best coupling for your project.

Standard pipe joints

- FWC coupling (GRP sleeve with full face EPDM/NBR gasket)
- DC coupling (GRP sleeve with EPDM sealing ring)

Special pipe joints

- Restrained pipe joint (axially restrained coupling with full face EPDM/NBR gasket, overlay joint)
- Mechanical coupling (steel or stainless steel sleeve with EPDM/NBR gasket)
- Adapter coupling (GRP sleeve with EPDM gasket)
- Sleeve coupling (EPDM gasket)
- Masonry coupling (GRP sleeve)

5.1 Standard Pipe Joints (FWC and DC Couplings)

HOBAS Pipes are generally supplied to the construction site with one coupling pre-mounted. Before joining pipes, check that the parts are correctly and securely in place.

When installed underground, the pipes must lie on the bedding over their entire length, except for the bell holes under the coupling. Point and line loads are not permissible. The FWC coupling can be used both for pressure and gravity pipelines. The DC Coupling can be used for pipelines without internal pressure from DN 150 through DN 300.

Mounting steps for standard joints

1 Cleaning the sealing elements

Immediately before joining the pipes, remove any dirt from the surfaces to be joined and in particular the sealing elements in the area of the grooves.

2 Applying the lubricant

Next apply lubricant to the spigot and gasket in order to minimize the force required for mounting. Soft soap can be used as lubricant. It is important to ensure that only the soap-based lubricant recommended by HOBAS is used. More lubricant can be supplied if required. Do not under any circumstances use oil-based lubricants.

3 Joining the pipes

When moving the pipes in the direction of the axis, ensure they are centric. Up to a nominal diameter of around DN 300 they can be joined by hand, and larger ones with the help of levers, gripping tackle, winches, jacks, or excavator buckets. Make absolutely sure that the material is protected against damage during the joining operation.

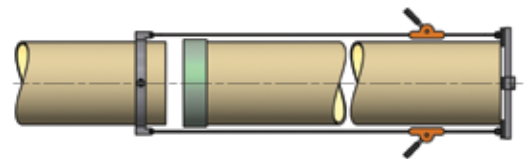

Fig. 28: Mechanical coupling aid

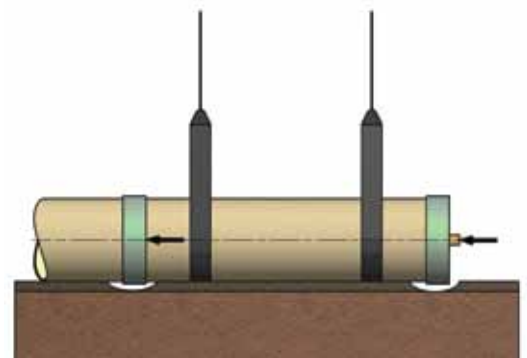

Fig. 29: Coupling with suitable equipment (slings not necessarily required)

Do not use any devices that cannot guarantee the pipes will be joined in a controlled manner or that could cause damage. The joining forces should only be applied to the pipe end. Do not apply any point loads. It is therefore always advisable to use a suitable means for distributing the loads (e.g. wooden blocks). Ensure that the coupling is not damaged in the process (Figure 28, Figure 29).

Not much force needs to be applied for joining, enabling the pipeline to be installed rapidly. Refer to Figure 30 for the joining forces required. Please consider that the forces may vary due to special requirements on site.

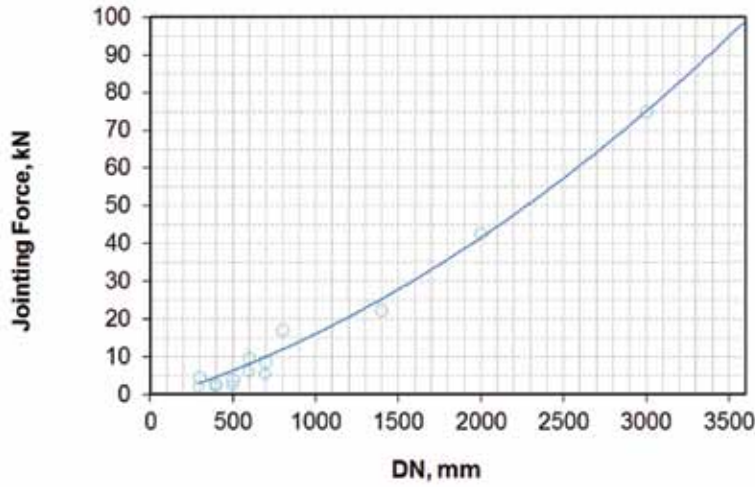

Fig. 30: Factory-set jointing forces with FWC couplings up to DN 3600

4 Angular deflection at joints

If installing a curved pipeline, HOBAS Standard Couplings can be used without any additional machining being required. The allowable angular deflection in the couplings is defined depending on the diameter (Table 7). With HOBAS Pipes, special preparation of the pipe ends can achieve larger angles than those shown in Table 7. As a result, the pipeline can be installed in an even smaller radius without any great effort, also at short notice. If this proves necessary, please contact HOBAS.

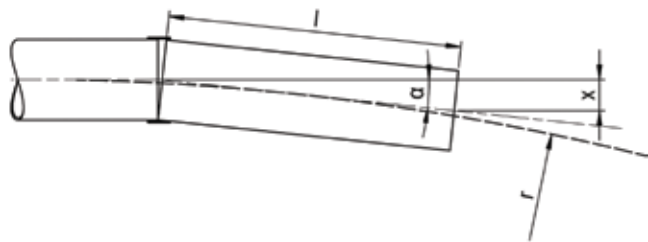

Fig. 31: Offset for curved installation

- l Pipe length
- x Offset
- α Deflection

Another option allowing pipelines to be laid with a smaller curve radius is to use short pipes (e.g. 1 m, 2 m, or 3 m). Take the resultant forces occurring due to deflection in the pipeline into account. To achieve the necessary angular deflection, the pipe end is offset from the center axis by the length x in relation to the pipe length. Refer to Table 8 for details of the curvature radius and offset.

Angular deflection relative to pipe diameter	
Diameter (mm)	Maximum deflection
< 600	3°
600 to < 1000	2°
1000 to < 1900	1°
≥ 1900	0.5°

Table 7: Angular deflection relative to pipe diameter

Pipe length, l (m)	6	3	2	1	6	3	2	1
	Curvature radius, r (m)				Offset, x (mm)			
Deflection, α (°)								
0.5	688	344	229	115	52	26	17	9
1.0	344	172	115	57	105	52	35	17
1.5	229	115	76	38	157	79	52	26
2.0	172	86	57	29	209	105	70	35
2.5	137	69	46	23	262	131	87	44
3.0	115	57	38	19	314	157	105	52

Table 8: Curvature radius and offset as a function of angular deflection and pipe length

5.2 Flanged Joints

Loose and integral flanges should also not result in any longitudinal forces or bending moments being transmitted to the pipeline. Ensure in particular that the pipe axes do not become offset and the pipes are therefore supported accordingly. Once bolted, the flanges must not cause the pipeline to be aligned. Tightening the bolts is only intended to seal the joint. Flange bores comply with EN 1092-1. Refer to the HOBAS Brochure "Technical Product Data" for the flange dimensions available.

Where pressure pipes are used, the nominal pressure class of the flanges selected must be at least the same as the pipeline's system pressure. Various suppliers have flanged joints depending on the diameter up to a maximum nominal pressure class of 6 to 16 bar. Flanged joints can also be used for joining to other pipe materials and fittings. The GRP flanges used have a flat facing. In the case of large diameters, it is advisable to use steel loose flanges, as the flange rings can be aligned more easily when mounting them on the construction site.

Mounting steps for flanged joints

1 Cleaning and inspection

Clean the front of the flange, groove, and rubber gasket carefully and check for any damage.

2 Aligning the flanges

After inserting the rubber gasket, align the flanges so the facings are parallel, insert the washers and bolts, and tighten them. All the parts must be clean and lubricated to enable them to be tightened uniformly.

3 Tightening

Tighten the bolts in the standard sequence (as shown in Figure 33) to prevent any uneven loads from being applied to the flanges.

The flange manufacturers specify the maximum tightening torque. Do not exceed these levels under any circumstances, otherwise the flanges could be permanently damaged. The bolt tightening torques allowed differ however in relation to the type of gasket used (flat or profile gasket).

Flange rubber gaskets

HOBAS recommends using profile (full face) gaskets for flanged joints. If other gaskets are considered, check their suitability. A profile gasket is flatter and does not require a groove in the flange facings.

A major advantage of profile gaskets (Figure 32) is, that the sealing and residual load effect can be achieved with low bolt tightening torque.



Fig. 32: Profile gasket

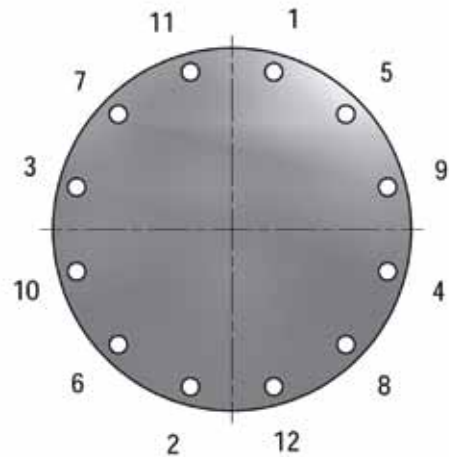

Fig. 33: Standard sequence for tightening the bolts

If the recommended profile gaskets are used, the tightening torques are much lower than for flat gaskets. To achieve the maximum bolt tightening torque, tighten the flange bolts successively in uniform steps of 25 Nm until the defined bolt tightening torque is reached.

5.3 Mechanical Couplings

Mechanical couplings are used when connecting pipes of different materials, repairing pipes, or joining a finished pipeline. The main advantage is the fact that they can be opened in order to push the coupling over the pipeline. As a result, short pipe sections can easily be replaced with mechanical couplings or used as inspection and maintenance ports in above-ground installations. The mechanical coupling consists of a (stainless) steel sleeve with a mechanical bolted connection and sealing element made of EPDM (NBR on request). For applications and dimensions available, please refer to the HOBAS Brochure "Technical Product Data, Gravity Pipe Systems PN 1" or contact HOBAS. Irrespective of the corrosion protection on the coupling, it should also be protected with a polyethylene band. Follow the supplier's instructions for installation at all times.

5.4 Adapter Couplings

Mechanical coupling

Mechanical couplings (Figure 34) are also used as adapter couplings. Even if the pipes' outside diameters are slightly different, mechanical couplings can still be used.

GRP coupling

A GRP coupling (Figure 35) can be used as an adapter coupling for a PVC pipe up to DN 300.

Sleeve

The sleeve (Figure 36) is a coupling system that is used for installation in gravity applications. It can also be used for joining pipes both of the same and different materials.



Fig. 34: Mechanical coupling



Fig. 35: GRP coupling



Fig. 36: Sleeve

5.5 Connecting to Structures

When connecting pipes to structures, ensure that flexibility is maintained in the joint to compensate for any possible differences in settling between the structure and pipeline (see Figure 37, Figure 38). Several options are possible for connections with a masonry coupling, structural adapter, or wall duct (see Table 9 and Figures 39 to 45). If couplings are used, a flexible support is created, thus preventing stress in the pipe as a result of different degrees of settling (e.g. between the structure and pipe). The coupling should be integrated as a wall sleeve and located as near as possible to the structure.

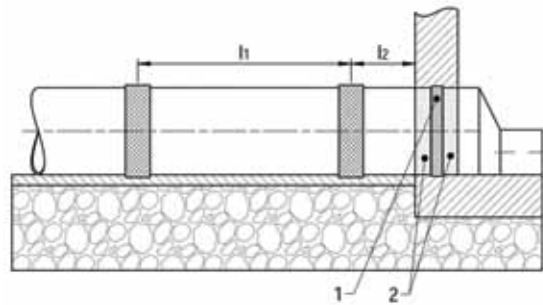

Fig. 37: Connection to buildings with structural adapters

- l_1 Length rocker pipe (1 – 2 m)
- l_2 Length joining pipe (max. 0.4 m or DN/2000 m; whatever is larger)
- 1 Wall collar or thrust ring
- 2 Structural adapter / wall duct sanded, optional with sealing tape (Bitumen)

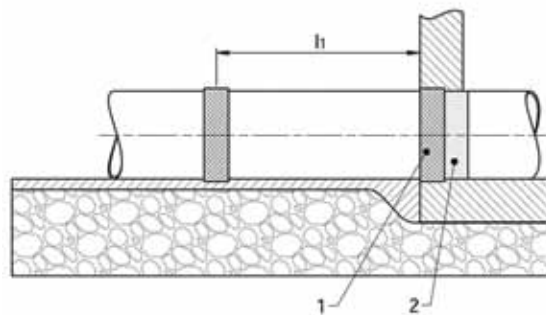

Fig. 38: Connection to buildings with masonry couplings

- l_1 Length rocker pipe (1 – 2 m)
- 1 Structural adapter
- 2 Pipe sanded outside, optional with sealing tape (Bitumen)

Type	Nominal diameter	Description
Masonry couplings		
A	DN 150 - 3600	- sanded - optional sealing tape
B	DN 150 - 3600	- sanded - thrust ring - optional sealing tape
C	DN 150 - 3600	- sanded outside - wall collar - optional sealing tape
Structural adapters / masonry duct		
The standard length is 0.5 m or 1 m up to DN 1100, and 0.5 m or 1.5 m for DN 1200 and over, depending on national regulations. Other lengths can be supplied on request.		
E	DN 150 - 3600	- sanded - with thrust ring - optional sealing tape
F	DN 150 - 3600	- sanded - optional sealing tape
G	DN 150 - 3600	- sanded - wall collar - optional sealing tape
Manhole liners		
D	DN 150 - 1200	Manhole liners are made of polypropylene, polystyrene (< DN 300), or GRP (> DN 400). They have a water barrier on the outside or quartz sand coating, depending on the manufacturer.

Table 9: Masonry couplings, structural adapters, masonry duct and manhole liners

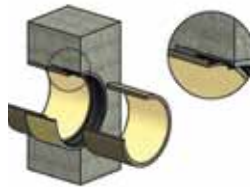

Fig. 39 : Masonry coupling Type A

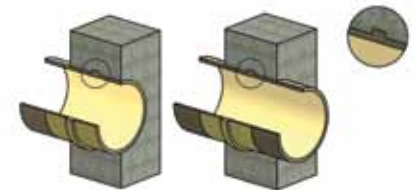

Fig. 43: Structural adapters Type E (2 options)

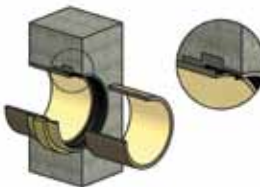

Fig. 40: Masonry coupling Type B

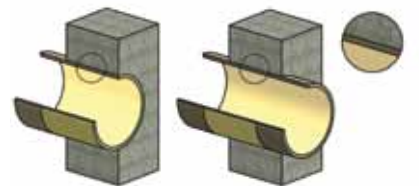

Fig. 44: Structural adapters Type F (2 options)

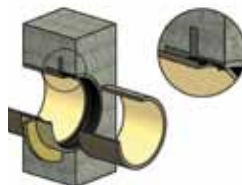

Fig. 41: Masonry coupling Type C

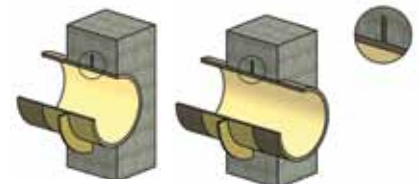

Fig. 45: Structural adapters Type G (2 options)

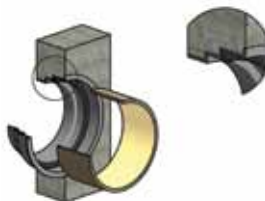

Fig. 42: Manhole liners Type D

5.6 On Site Pipeline Connection

There are two options for connecting pipelines to HOBAS Pipes on site:

- Glued and bolted saddles
- Connection saddles from other manufacturers

Glued and bolted saddles

A major advantage of HOBAS GRP Pipes is that working them in the field is easy. HOBAS supplies glued and bolted saddles for connecting sewers on site. Where saddles are glued, the outlet is generally at an angle of 45° or 90°. Saddles for a flush fit on the inside of the pipe can also be manufactured on request. Dimensions may vary according to national legislation. They can be connected to other materials e.g. to vitrified clay and PVC.

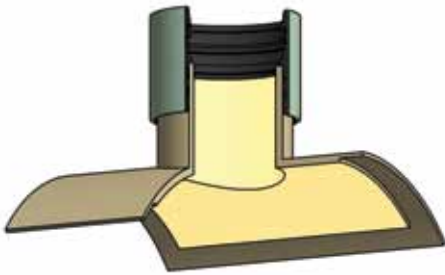

Fig. 33: Glued saddle with 90° outlet, dimensions as in HOBAS Brochure "Technical Product Data"

The glued saddle (see Figure 46) is a prefabricated part used to connect the sewer to the required point in the pipeline. Use a circular saw (with a carbide tipped or diamond blade, not a metal one) or drill to cut out the area in the pipe required for the connection. By contrast, no gluing is required for the HOBAS Bolted Saddle. It is connected to the main pipe by bolting onto a plate and using a full face gasket to seal it on the inside. Refer to Appendix for instructions on fitting glued and bolted saddles.

Connection saddles from other manufacturers

Various manufacturers supply mechanical connections for thin-walled pipes that are inserted into the drilled hole in the HOBAS Pipe and sealed with a bolted connection. Only 90° outlets are available for these connection saddles. Contact the supplier for information on installation. HOBAS is happy to support with appropriate supplier.

6 Manholes, Tanks, Fittings, and Special Structures

6.1 Installing Manholes

The procedure for installing HOBAS Manholes, which are generally supplied as one-piece, seamless, prefabricated GRP shafts, is just as simple, safe, and fast as installing HOBAS Pipes.

Pits

The pits excavated must be secure and of such a size that the shaft components can be installed properly and safely. In particular, observe the necessary working space breadth as indicated in the statutory accident prevention regulations. Furthermore, the bottom of excavated pit must meet the demands of good compaction.

Bedding and stability

When installing pipes towards a manhole, do not embed the last pipe or connector. You have to make a suitable bell hole for the manhole. Prepare and compact the bell hole including bottom zone such that different settling between the manhole and pipe cannot occur later. The manhole is generally placed on compacted gravel bedding (larger manholes on lean concrete). Please note the design specifications. After checking the connection height the bedding with appropriate material (e.g. gravel/crushed stone 8/16 mm) or blinding concrete can be conducted.

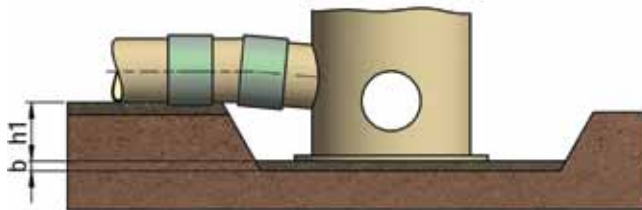

Fig. 47: Manhole installation

- h1 Connection height
- b Bedding gravel/crushed stone (approx. 50 mm) or blinding concrete (lean concrete) with gravel layer (min. 100 mm)

Connection

Before connecting the manhole, check that the connector on the manhole is aligned with the pipe to be joined, and if necessary adjust its location by altering the blinding layer depth. Installing manholes is similar to installing pipelines with the help of suitable equipment, e.g. a winch. Do not push the manhole.

After installing the manhole, check the following:

- 1 The coupling and gasket are properly seated
- 2 The gradient
- 3 No loads are present between joint, manhole and pipe (use connector)
- 4 The stability of the manhole

Backfilling and compacting the soil must be done evenly to prevent the manhole from becoming displaced and to ensure it is stable. Embedding and covering the connecting pipes and manhole must also be done evenly to prevent different degrees of settling. Do not place the manhole on a cured concrete floor, as this could lead to point loads and therefore damage. Install it on a concrete floor with an intermediate gravel layer of at least 100 mm. If flat concrete covers or concrete cones are used, backfill the soil around the manhole right up to under its top edge. The bedding surface must be level and without any point loads being transmitted to the concrete cover (lay fine crushed stone if necessary).

If a manhole is installed underneath traffic areas, structural analysis is required. HOBAS will be happy to provide support with structural calculations. If a structural engineering analysis is available, the manholes can be installed accordingly. Where no structural analysis exists for the pipes, ensure that the concrete cover transmits the traffic loads to the backfill. It therefore has to be laid evenly. Prevent any point loads. In this case, avoid any direct load contact between the concrete cover and manhole wall.

6.2 Installing Special Structures

Installing special structures is similar to laying pipelines. Always ensure that they are well embedded and compacted, as this work has a direct effect on the pipe/soil system's stability. In the case of drop structures, tangential or dome manholes, combined sewer overflow chambers, and special structures, concrete casing may be required. If in doubt, please consult HOBAS.

6.3 Installing Tanks

Treat vertical buried tanks the same as manholes. Horizontal tanks are made out of pipes and are generally to be installed in the same way. Please note the following special features:

- Once connectors, outlets, etc. are installed, changes in structural behavior can occur compared to a horizontal pipeline. To prevent stress peaks, it may prove necessary, depending on the load, to take additional action, e.g. encase them in concrete.
- Special equipment may also be required for transporting and lifting them during installation, depending on their size. Pay particular attention here to the accident prevention regulations and the tanks' load capacity.
- When installing tanks, generally lower them into the pit. Do not push, press, or roll them.
- After covering them with soil, ensure that they are embedded and the backfill is compacted evenly, otherwise settling and deflection could occur.

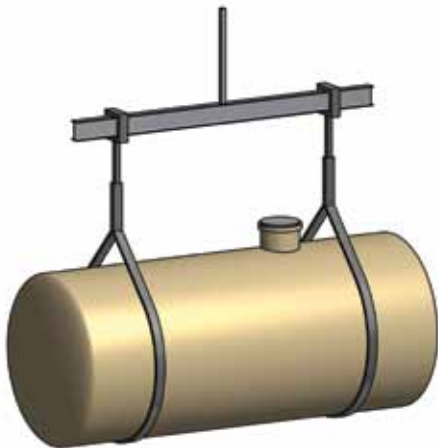

Fig. 48: Handling of tanks

6.4 Installing Fittings

Fittings are generally made of pipe segments. The same requirements therefore apply to their installation and embedment as to the pipe's. Depending on the actual fitting involved, it may be difficult to apply the forces required to join it to the pipe. If so, you can generally work with installation aids to enable fittings to be joined in a controlled way. Winches or jacks have proved useful in the field.

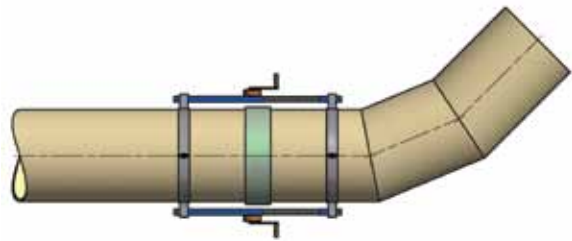

Fig. 49: Installation aids for fittings

7 Pressure Pipelines

Longitudinal forces (N) due to internal pressure [kN]		
DN	1 bar	9 bar
150	1.9	17.2
200	3.3	30.0
250	5.1	45.6
300	7.3	65.3
350	9.7	87.6
400	12.8	114.8
450	16.0	144.4
500	20.0	179.6
550	21.4	192.6
600	26.8	241.1
650	29.8	268.2
700	36.5	328.8
800	47.8	430.1
860	52.6	473.0
900	60.5	544.9
960	65.3	587.9
1000	74.8	673.3
1100	85.8	771.9
1200	107.7	969.3
1400	146.6	1319.0
1500	160.4	1443.4
1600	191.6	1724.6
1800	242.7	2184.6
2000	301.4	2712.7
2200	363.1	3267.5
2555	468.0	4211.8
3000	645.1	5806.1

Table 10: Forces in axial direction per 1 bar pressure as well as for 9 bar test pressure (1.5 x PN 6) at SN 10000 pipes

Hydrostatic and hydrodynamic internal pressure causes additional forces to act on the pipe system at:

- Fittings (e.g. bends, tees, wyes, reducers, etc.)
- Changes in direction caused by pipes deflected in the coupling

The forces occurring in pressure pipes and fittings are shown in Figure 50. Where there are bends or changes in direction due to pipe deflection in the coupling, use equation 3 to calculate the resultant force. Use equation 2 to calculate the force in the axial direction for tees or shut-off devices (e.g. valves). When calculating the thrust force, take the test pressure into consideration. The thrust forces due to the test pressure in the axial direction depend on the pipe diameter and internal pressure (Table 10).

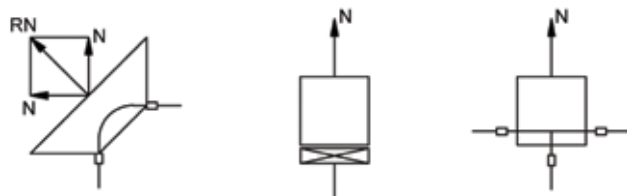

Fig. 50: Thrust forces in pipelines

$$N = \frac{P \cdot ID^2 \cdot \pi}{40} \tag{2}$$

$$RN = N \cdot 2 \cdot \sin \frac{\alpha}{2} \tag{3}$$

- P Test pressure [bar]
- ID Inside diameter [mm]
- N Force in axial direction [N]
- RN Resultant thrust force [N]
- α Deflection [°]

7.1 Concrete Thrust Blocks for Buried Fittings

HOBAS Pressure Fittings are designed for internal pressure. Concrete thrust blocks support the fittings and transmit thrust forces into the soil to prevent longitudinal forces from being transmitted into the pipeline and avoid movements of the pipeline. The dimensions of the concrete thrust blocks have to be selected based on the thrust forces occurring and the native soil stability. It is the designer's responsibility to determine the dimensions of the concrete thrust block and steel reinforcement. When pipelines are buried, thrust forces are dissipated through the pipes themselves into the soil. Concrete thrust blocks are normally only required for fittings (Figure 51, Figure 52). The couplings on the fittings always have to be completely encased by concrete to ensure flexible connections. References to applicable standards for calculations are to be found in Section 15.

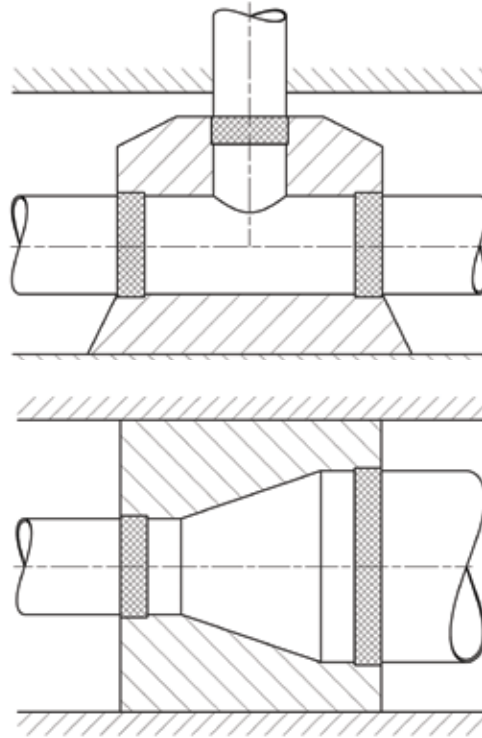

Fig. 51: Illustration of concrete thrust blocks for tees and reducers

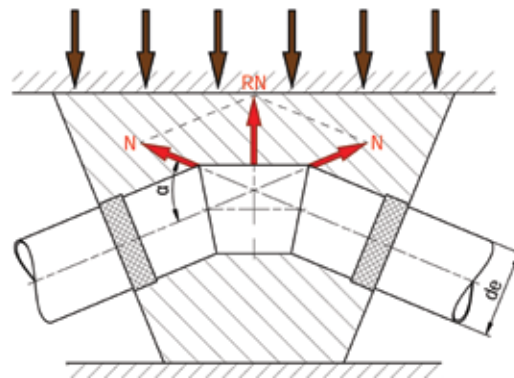

Fig. 52: Concrete thrust block with resultant forces at the bend

7.2 Restrained Joint

Using restrained joints can avoid to install concrete thrust blocks, as the resultant forces due to internal pressure are absorbed by the pipeline system and its joining elements. This method of installation causes the forces in axial direction to be dissipated by the casing friction between the pipe and soil. The pipeline lengths to be longitudinally restrained therefore depends on the nominal diameter, test pressure, angle of deflection, friction between the pipe wall and soil and groundwater conditions. Use equations 2 and 4 to calculate the resultant force and soil resistance. For the pipe length l_s to be installed axially restrained on both sides of the bend, use equation 8.

7.3 Thrust Forces in Pipelines Installed Above Ground

Where pipelines are to be installed above ground, it is the designer's responsibility to select supports and pipe clamps (see Section: 4.2 Above-Ground Installation) taking the maximum thrust forces occurring in the pipeline and fittings into account. In addition, any vibrations in the pipelines also have to be taken into consideration.

7.4 Accessories

Accessories, such as valves, gates, butterflies, etc. must be supported such that no longitudinal and thrust forces are transmitted to the pipeline.

$$E = \text{allow } \sigma_h * 2 * D_e * \pi \quad (4)$$

$$G_B = D_e * h * \gamma_B * \frac{2}{3} \quad (5)$$

$$G_M = \gamma_M * \frac{ID^2 * \pi}{4} \quad (6)$$

$$G_R = 9,81 * \frac{\gamma_R}{1000} \quad (7)$$

$$l_s = \frac{N - E * (\mu + \cot \frac{\alpha}{2})}{\mu * (2 * G_B + G_W + G_R)} \quad (8)$$

N	Force in axial direction [kN]
E	Soil resistance [kN]
allow σ_h	Allowable horizontal soil pressure [kN/m ²]
allow $\sigma_h = 40$ kN/m ²	for crushed stone and gravel or sand, compact
allow $\sigma_h = 30$ kN/m ²	for sandy gravel or sand, and for till, semi-solid loam and clay
l	Pipe length (6 m) [m]
D _e	Pipe outside diameter [m]
μ	Coefficient of friction [-]
$\mu = 0.5$	for non-cohesive sands, gravels, and tills
$\mu = 0.25$	for very clayey sand, sandy clay, marl, clay, loam and loess loam, and clay of at least semi-solid consistency
$\mu = 0.4$	recommended coefficient of friction for GRP pipes in sand or gravel bed
G _B	Weight of soil above pipe [kN/m]
G _W	Weight of water fill [kN/m]
G _R	Weight of pipe [kN/m]
h	Average pipe cover on the pipeline section to be supported [m]
γ_B	Specific weight of the trench fill (e.g. 18 kN/m ³) [kN/m ³]
γ_M	Specific weight of the medium (e.g. 10 kN/m ³ for water) [kN/m ³]
γ_R	Specific weight of the pipe (20 kN/m ³) [kN/m ³]
α	Deflection [°]
M _Z	Pipe weight [kg/m]
l _s	Pipe length to be supported
ID	Inside diameter [m]

8 Leaktightness Testing of Gravity Pipelines

8.1 General

Sewers and manholes must be tested for leaktightness to EN 1610 in order to protect soil and groundwater from contamination, but also to prevent groundwater entering the sewer systems, which places an undue burden on wastewater treatment plants. Leak testing procedures are to be found in the ATV M 143 standard, Part 6, or can be based on local regulations. Take the equipment requirements in the regulations into consideration and take appropriate safety precautions. If pneumatic testing is conducted special precautions for safety measures have to be considered. Testing of leak tightness with water is the preferred method.

Use standpipe or other suitable pressure gauges for testing. Test sewers at a pressure of 0.1 to 0.5 bar, measured above the lowest elevation covered by water in the pipeline section to be tested. The test duration is 30 minutes. During this time, maintain the test pressure by constantly refilling the amount of water used if necessary. Refer to Table 11 for the allowable make-up water per meter for some of the diameters of pipes with manholes and couplings.

8.2 Hydrostatic Testing for Sewers

Individual pipe joints, pipeline sections, or entire reaches can be tested. Pipelines that are not embedded or only partially covered must be prevented from moving with suitable means of restraint. Pay particular attention to this with fittings. Fill the pipeline slowly at normal pressure and without air from the lowest elevation. At the highest elevation in the test section, ensure that a large enough vent is provided to enable the air contained in the pipeline to escape. After completing the filling process, leave the pipeline for about 1 hour at 0.5 bar water pressure to give the air still remaining in the pipeline (wyes, coupling chambers) a chance to be expelled gradually. The air that does not escape can reach the water temperature during this period. This prevents changes of volume in the pipeline as far as possible.

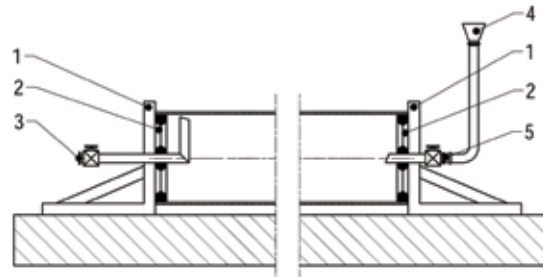

Fig. 53: Temporary valve for leak test of pipe sections

- 1 Bracing for pressure test plate and pipeline
- 2 Pressure test plate for venting
- 3 Vent connection
- 4 Funnel for gravity filling
- 5 Filling nozzle

Leak test to DIN EN 1610																	
Test pressure		Initial filling time				Test duration				Allowable make-up water l/m ² wetted inner surface							
10 - 50 kPA (0.1 - 0.5 bar)		1 h				30 ± 1 min.				0.15 (pipelines) 0.2 (pipelines and manholes) 0.4 (manholes and inspection chambers)							
Allowable make-up water e.g. SN 10000 N/mm ²																	
DN	150	200	250	300	350	400	500	600	700	800	900	1000	1200	1400	1600	1800	2000
Inside diameter	159	208	258	308	357	406	505	587	685	783	882	980	1175	1376	1566	1762	1958
Allowable make-up water l/m for pipelines and manholes	0.1	0.131	0.162	0.193	0.224	0.255	0.317	0.369	0.430	0.492	0.554	0.615	0.738	0.844	0.983	1.106	1.229
Allowable make-up water l/m for pipe and coupling testing	0.075	0.098	0.121	0.145	0.168	0.191	0.238	0.276	0.323	0.369	0.415	0.462	0.553	0.648	0.738	0.83	0.922

Table 11: Allowable make-up water for leak test to EN 1610

8.3 Pneumatic Testing to EN 1610

In the interest of safety, take special care during tests on large diameter pipes. Testing manholes and inspection chambers with air is difficult to carry out in practice. Refer to table 12 for the test duration for pipelines without manholes and inspection chambers, taking the pipe diameters and test methods (LA; LB, LC; LD) into consideration. The customer should define the test method to be used. Use suitable air-tight seals to prevent measurement errors as a result of the test equipment. Note to EN 1610: Until you have gained adequate experience for testing manholes and inspection chambers with air, it is advisable to use test durations that are half as long as those for pipelines of the same diameter.

First maintain an initial pressure that exceeds the required test pressure by around 10 % for around 5 minutes. Then set the pressure for Δp to the test pressure indicated in the table for methods LA, LB, LC, or LD. If the pressure drop Δp measured after the test duration is lower than the figure given in the table, the pipeline complies with the requirements. The devices used to monitor the pressure drop must ensure measurement with a maximum allowable error of 10 % Δp . When monitoring the test duration, the maximum allowable error is 5 s.

Test method	p_0	Δp	t/test duration (minutes)						
	mbar (kPA)		DN 100	DN 200	DN 300	DN 400	DN 600	DN 800	DN 1000
LA	10 (1)	2.5 (0.25)	5	5	7	10	14	19	24
LB	50 (5)	10 (1)	4	4	6	7	11	15	19
LC	100 (10)	15 (1.5)	3	3	4	5	8	11	14
LD	200 (20)	15 (1.5)	1.5	1.5	2	2.5	4	5	7
K_p-value*			0.058	0.058	0.040	0.030	0.020	0.015	0.012

Table 12: Duration of test depending on test method and diameter

$$* t = \frac{1}{K_p} * \ln \frac{P_0}{P_0 - \Delta p} \quad K_p = \frac{12}{DN} \quad (9)$$

with a maximum of 0.058, where r is rounded to the nearest half minute for r - 5 min and the nearest whole minute for r > 5 min

t Test duration
 p_0 Pressure above atmospheric
 Δp Pressure drop

8.4 Pressure Test of Coupling

The pressure test of coupling involves checking the pipe joint with a device that seals the coupling gap from the inside pipe wall. Use 1 m pipe length as the surface to be tested.

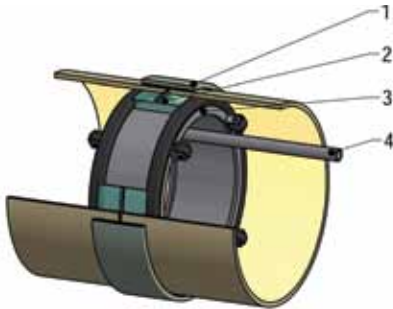

Fig 54: Illustration of coupling pressure tester

- 1 Coupling
- 2 Water
- 3 Rubber Sealing
- 4 Filling hose

When selecting the coupling tester, please note the following:

- HOBAS Centrifugally Cast Pipes are clearly defined by the outside diameter. The inside diameter largely depends on the pipe stiffness and pipe wall thickness.
- The installation quality and therefore the pipe deflection and wall thickness tolerances determine the tester to be selected.

In the field, it has proved practical to carry out the test immediately after joining the pipes and taking the machine along as installation progresses. It is advisable to consult HOBAS here.

Testing with air

When conducting a test with air, ensure in particular that the safety requirements are met, as air is a compressible medium and negligence could lead to higher risks. The test site consists of the sealed area and the pipe volume. Equipment with suitable sealing devices for pipes should therefore preferably be used. When sealing the pipe with test bladders, ensure the bladder is of the right shape for the intended test site.

9 Testing of Pressure Pipelines

9.1 Basic Principle

Once pressure pipes have been laid, a pressure test is generally required. Such tests serve to prove that the pipes, pipe joints, and pipeline parts are leak tight, and that the pipeline is securely in position. The requirements in the EN 805 standard should be considered.

9.2 Preparation and Safety

The pipeline must be laid in compliance with the design specifications and installation instructions. Do not install any safety valves, blow-out disks, or similar for the test. During the test, all the valves in the system to be tested must remain open. Ensure that the test pressure cannot cause any changes in the pipeline's position. Where joints are not longitudinally restrained or expansion joints do not have sealed ends, secure the pipeline adequately at the ends, bends, wyes, deflections in the couplings, and shut-off devices. In straight pipeline sections, it is enough to weigh down the pipes with soil after they have been well embedded. For pressure testing, use two devices with adequate reading accuracy that operate independently of each other. One of them should document the results where possible (pressure recorder). Before starting the test, check that all the precautions relevant to safety have been taken.

9.3 Test Sections

The length of the test section to be selected depends on the local conditions. Test sections with small pipe diameters should not generally exceed 500 m and large nominal diameters 1,500 m. If in exceptional cases you are testing a section consisting of pipeline parts with two different nominal pressures (e.g. a valley crossing), select the section length such that the test pressure of one part of the pipeline does not exceed 1.5 times the pipe system's nominal pressure at any time. When selecting the test section, ensure that the test pressure is reached at the lowest point in the pipeline and at least MDP + 1 bar is applied at the highest.

9.4 Filling the Pipeline

Fill the pipeline with water, or drinking water for potable water pipes, to ensure that it is free of air. It is therefore advisable to fill the pipeline from the lowest point slowly enough so the air can escape easily out of the vents of suitable size at the highest points. If you have to carry out pressure tests at outside temperatures around freezing point, arrange appropriate precautions with the construction site management. When there is frost, do not leave any water in the pipeline. Stop pressure testing in such cases and drain the pipelines without delay. After filling, flush the pipeline again under slight pressure if at all possible to ensure it is completely de-aerated, until the water coming out of the vent does not contain any bubbles. Before the test, close all the openings pressure tight. To prevent damage to the pipeline when filling, do not exceed the following quantities.

Allowable filling quantities												
DN	150	200	250	300	350	400	500	600	700	800	900	1000
Amounts l/s	1	1.5	2	3	4	6	9	13	18	24	30	38

Table 13: Allowable filling quantities

9.5 Applying Internal Pressure

Pressure testing consists of a preliminary and a main test.

9.5.1 Preliminary Test

The purpose of the preliminary test is to halt the change in volume in the pressure pipeline dependent on the internal pressure, time, and temperature to such an extent that the subsequent main test can give a clear indication of the test section's tightness. Gradually increase the internal pressure of the filled pipeline at least until reaching operating pressure. Do not however exceed system testing pressure. Maintain the preliminary test pressure for at least 6 hours. If the pressure drops, pump again every hour. Should inadmissible changes in position or leaks occur in any part, depressurize the pipeline and remedy the cause. In individual cases when agreed with the customer, you may omit the preliminary test.

9.5.2 Pressure Drop Test

Air in the pipeline reduces the accuracy of a pressure test with water. A leak may be assumed in most cases. To determine the air remaining in the pipeline, a pressure drop test can be used. The designer specifies how it is to be performed. Special considerations may however be required, depending on the pipe quality selected and environmental conditions.

9.5.3 Main Pressure Test

After completing all the preparations, clarifying the safety requirements and carrying out the preliminary test and, if necessary, the pressure drop test, the main test can start. The designer decides the test method:

- Water loss test
- Pressure loss test

Immediately after successful preliminary testing, you can generally carry out the main test. Increase the pressure uniformly to the system test pressure (STP). In individual cases with difficult soil and installation conditions a lower test pressure than that indicated in the above table where it would appear advisable in view of the thrust block or anchor design may be selected. The test pressure should be achieved in the lowest point of the pipeline and it should not be lower than 1.1 times the maximum design pressure (MDP) in any case at the highest point. Observe temperature effects in particular when evaluating the test. If there are any leaks, eliminate the cause and repeat the test.

Test pressure with water hammer calculation:

$$STP = MDP + 1 \text{ bar} \quad (10)$$

STP System test pressure [bar]

MDP Maximum design pressure (incl. water hammer assessed or calculated) [bar]

System test pressure	Maximum design pressure	
	MDP ≤ 10	MDP > 10
At the testing point	1.5 times maximum design pressure ¹	Maximum design pressure ¹ + 5 bar
At lowest point in test section	< 1.5 MDP	< 1.5 MDP
At highest point in test section	> 1.1 MDP	> 10 bar

Table 14: System test pressure (STP) without calculation of the water hammer (water hammer only estimated)

¹ In gravity pipelines, the maximum design pressure corresponds to the static pressure.

Test duration: 1 h Allowable pressure drop: 0.2 bar

Example of a procedure to EN 805 for determining the allowable water loss

Increase the pressure in the pipeline up to the test pressure, ensuring that the test and measuring equipment is completely vented. Maintain the pressure for an hour or to the designer's specifications. During this testing time, monitor the water volume that has to be pumped in to maintain the system test pressure. Alternatively, you can remove a measurable water volume ΔV from the pipeline, and measure the pressure drop Δp occurring. Then compare the water volume ΔV removed related to the pressure drop Δp with the allowable water loss ΔV_{max} . Equation 11 applies to calculating the allowable water loss at the end of the first hour. If water tightness cannot be proved using this method within an appropriate time, check whether the specific project conditions would allow an alternative test in compliance with Appendix A 27 of EN 805.

$$\Delta V_{max} = 1.2 * V * \Delta p * \left(\frac{1}{E_w} + \frac{ID}{e * E_R} \right) \quad (11)$$

ΔV_{max} Allowable water loss, l

V Volume of the test section, l

Δp Measured pressure drop (max. 20 kPa for plastic pipes)

E_w Compressive modulus of water, kPa

ID Inside diameter, m

e Wall thickness, m

E_R Pipe wall's modulus of elasticity in hoop direction, kPa

1.5 Allowable factor for admissible air content prior to main pressure test

9.5.4 Short Test

A short test should be agreed with the customer and designer. If the following parameters are met during the preliminary test on reaching the system test pressure, the test is deemed passed.

STP	Test duration	Allowable pressure drop
1.5 x MDP	1 hour	0.5 bar

Table 15: Parameter of the short-term test

10 Cutting of Pipes On Site

When handling cutting tools, take due care to ensure health and safety in the workplace, and comply with the applicable regulations. It is also important when working with the materials (cutting, drilling, gluing, etc.) to take the relevant conditions on site into consideration.

Prior to starting, check the local conditions to determine what noise and dust could occur during work and the precautions to be taken both for the person carrying out the work and the environment.



1. Restrain pipes and fittings to prevent them from rolling or moving away, etc. and remove any dirt from the surface. Support the pipe or fitting, enabling the cut to be made in one operation without stopping.
2. Determine the cutting line and mark with a felt pen.
3. Cut preferably with a slotted diamond blade; use personal protective equipment (safety goggles, gloves, noise protection, dust mask). You do not need to apply additional pressure when cutting - the machine weight is adequate.
4. Chamfer the cut edge on the inside of the pipe with a grinding disk. The cutting edges have to be rounded.
5. Chamfer the cut edge on the outside of the pipe and round the edges with a diamond grinding disk (Figure 55).

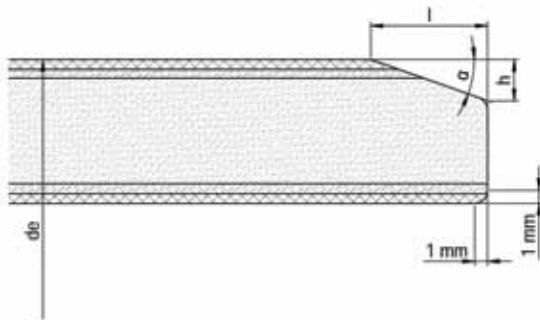

Fig. 55: Illustration of the required chamfering of the pipe spigot

- l Length
- h Height
- α Chamfer angle
- de Outside diameter

Diameter, mm	Angle α, °	Height, mm	Length, mm
≤ 500	20	2 - 4	8 ± 2
> 500 ≤ 1000	20	4 - 6	13 ± 3
> 1000 ≤ 1500	20	6 - 8	19 ± 3
> 1500 ≤ 2555	20	8 - 11	26 ± 4
> 2555	20	11 - 15	30 ± 4

Table 16: Dimensions of chamfering of the pipe spigot dependent on the pipe diameter

11 Repair Work

If the pipeline is damaged to such an extent that it requires repairing, follow the procedure below. Please consult HOBAS if in any doubt about the extent of the damage or suitable repair options.

11.1 Assessing Damage

Outer surface damage:

HOBAS Pipes have a resin-rich protective outer layer. If slight scratches, scraping, or scuff marks can be detected here, they do not generally have any impact on the component's service life.

Inner surface damage:

Slight scraping marks are harmless. Damage with the wall structure broken open and glass fibers exposed however needs to be repaired. If there are cracks and mechanical damage, please consult HOBAS if deemed necessary.

11.2 Replacing a Defective Pipe Section

When a pipe segment is mechanically damaged, determine the exact extent and location. If a replacement is necessary, cut out the damaged pipe section including a safety margin of approximately 300 mm distance on each side of the damage with a circular saw. Then cut a repair pipe to a length that is around 10 – 20 mm shorter than the damaged section cut out of the pipeline. Chamfer the cut edges. Calibrating the spigots is not necessary.

When using special mechanical couplings, they can be slipped over the exposed pipe ends immediately after the preparation work is completed. Now insert the repair piece. Slip the mechanical couplings back to the previously marked mounting depth and lock them. To make installation easier, also use a lubricant on the mechanical couplings. Please note the instructions provided by the mechanical coupling manufacturer.

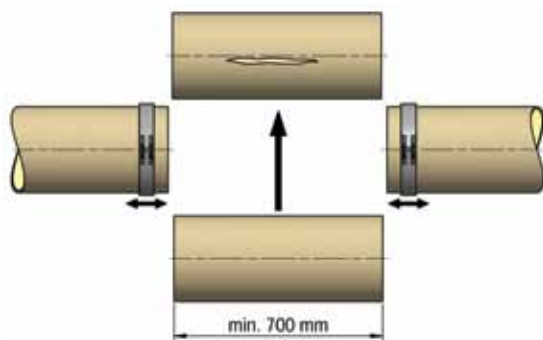

Fig. 56: Replacing damaged pipe with mechanical couplings

Repair couplings

If the damaged area of the pipe is only very small, a repair coupling can be mounted for gravity applications. The type of coupling used depends on the actual damage and the application for the pipeline. Before mounting the repair coupling, clean the damaged area. The coupling can then be opened up, placed round the damaged area, and tightened. Please note the instructions provided by the repair coupling manufacturer.

Repair laminate

Given the special skills and requirements involved, only qualified personnel may repair pipes with a laminate. Proof of such qualifications is a DVS 2220 (German Welding Society) certificate. HOBAS Laminators all have the necessary qualifications and experience to carry out laminating work on the construction site. Please contact HOBAS if you require such services.

11.3 Removing a Pipe Coupling

Newly laid pipelines can be dismantled with an installation aid under favorable conditions. After removing the coupling, check whether the sealing lips have been damaged in any way. Replace the coupling if necessary. Ensure the force applied to remove the coupling is controlled to prevent the pipe material from being subjected to excessive stress. If a coupling is too tight, it is advisable to cut the laminate with a saw and replace it with a repair coupling. Make sure here that the pipe surface is not damaged. Another option is to deflect a pipe and swivel it out.

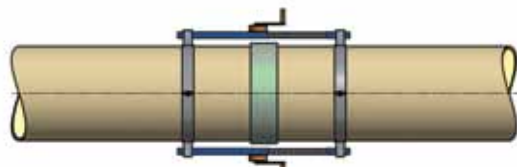

Fig. 57: Example of an installation aid for dismantling pipes

12 Special Installation

12.1 Double Pipes

Given their excellent properties, HOBAS Double Pipe Systems are becoming increasingly popular, above all in potable water protection zones. Pipe-in-pipes are normally pre-assembled before being supplied to the construction site.

Installation

Spacers with runners keep the carrier pipe in place. To maintain the pipeline's structural load capacity, at least two spacers are required per 6 m pipe. As various spacer models have different ratings and applications can vary, more spacers may also be used if necessary. Laying double pipes is basically the same as for standard pipes. The only difference when joining them is to start with the carrier pipe and check it before going on to the casing pipe.

Pressure and leak testing

When leak testing double pipes, please note the following special features. If only the carrier pipe is to be tested, proceed as described in the section: 8 Leak Testing. Given the forces acting during changes in direction, special precautions have to be taken for pressure tests. Please consult HOBAS about such projects. If you need to test the space between the casing and medium carrier pipes without filling the carrier pipe (backpressure), ensure that the carrier pipe is not loaded above its allowable collapse pressure. One procedure is to test the medium carrier pipe first, and then the carrier pipe and casing space at the same time. This ensures that the pressure is the same both in the carrier pipe and the casing space.

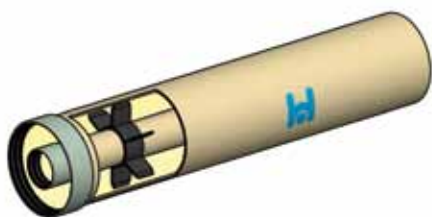

Fig. 58: Sectional view through the casing pipe incl. carrier pipe

12.2 Concrete Casing

The concrete for the casing can be placed by machine. Pour it evenly on both sides of the pipe. When pumping concrete, you have to work more carefully. Other flotation restraints and a stronger type of pipe may prove necessary here.

Refer to Table 16 as a guideline for the amounts of concrete used in installation. The dimensions of the concrete casing in compliance with Swiss standard SIA V190 are given in Figure 59.

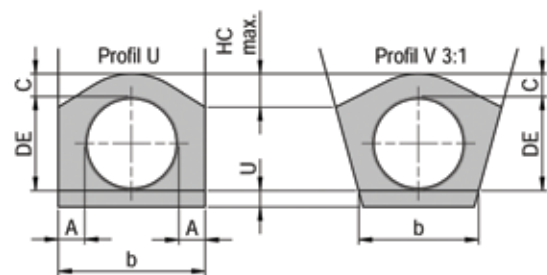

Fig. 59: Trench shapes acc. to SIA V190

Concrete required for embedded HOBAS Pipes*										
Nominal diameter	Outside diameter	Head height	Thickness of bedding	max. 0.25 (D _e + 2 c)	PROFILE U			PROFILE V 3.1		
					Bottom width	Encasing concrete incl. invert	Material displacement incl. invert	Bottom width	Encasing concrete incl. invert	Material displacement incl. invert
NW mm	DE mm	c mm	A = U	HC mm	b mm	m ³ /m	m ³ /m	b mm	m ³ /m	m ³ /m
200	220	100	200	105	620	0.252	0.290	504.4	0.270	0.308
250	272	100	200	118	672	0.288	0.346	544.9	0.309	0.367
300	324	100	200	131	724	0.323	0.406	585.3	0.348	0.431
350	376	100	200	144	776	0.360	0.471	625.8	0.389	0.450
400	427	100	200	157	827	0.396	0.539	665.4	0.429	0.572
500	530	100	200	182	930	0.471	0.692	745.5	0.513	0.734
600	616	100	200	204	1016	0.536	0.834	812.4	0.587	0.885
700	718	100	200	229	1118	0.615	1.020	891.8	0.677	1.082
800	820	100	200	255	1220	0.696	1.224	971.1	0.770	1.299
900	924	100	200	281	1324	0.782	1.452	1052.0	0.870	1.541
1000	1026	100	200	306	1426	0.868	1.695	1131.3	0.971	1.798
1100	1099	110	210	330	1519	0.983	1.932	1203.7	1.100	2.049
1200	1229	120	220	367	1669	1.160	2.347	1320.3	1.302	2.489
1400	1439	150	250	435	1939	1.568	3.194	1530.3	1.761	3.387
1500	1499	150	250	450	1999	1.636	3.401	1577.0	1.842	3.607
1600	1638	160	260	489	2158	1.872	3.980	1700.7	2.112	4.220
1800	1842	180	280	550	2402	2.290	4.956	1890.4	2.589	5.254
2000	2047	200	300	612	2647	2.750	6.041	2081.0	3.115	6.406

* Example. The thickness of the concrete casing must be adjusted to static requirements

Table 17: Concrete required for embedding HOBAS Pipes depending on trench shape

13 Installation Inspection

Immediately after laying in the trench, inspect the pipeline and couplings visually from the outside for damage. If any damage has occurred during the process, document it and, depending on how serious it is, contact HOBAS. Immediately after installing the pipeline, inspect it internally with a camera (CCTV) or if the diameter is large enough, on foot.

If inspection on foot is considered necessary, check for the following:

- Vertical pipe deflection
- Offset of pipe axis
- Coupling gap in case of angular deflection

Vertical pipe deflection

After parts of the pipeline have been installed and the pipe trench has been completely backfilled, vertical deflection can be measured. It is normally less than 2 % when the pipe is well bedded. If greater deflection occurs, it is a sign that the quality of the pipe bedding is not adequate.

Offset of pipe axis

The pipes should not be offset after installation and it must therefore be avoided.

Coupling gap in case of angular deflection

Determine the coupling gap to check whether the angular deflection of the pipeline is within the tolerances relative to the pipe diameter. If pipeline inspection after installation is to be carried out with a camera, any commercial robotic crawlers are suitable. Ensure that the pipeline does not sustain any damage as a result, e.g. from the crawler's wheels or cable. Where inspection on foot is considered necessary, ensure that the local safety regulations are observed. Note the low roughness of GRP pipes' inner surface in particular and take appropriate precautions, especially where pipelines have large gradients.



14 Cleaning Pipelines

Sewer pipes have to be cleaned in intervals depending on the degree of pollution. When HOBAS Pipes are used, it is not usually required as often because the smooth inner surface means that less sand and sludge is deposited or, if so, it is dislodged again more easily at higher flow rates.

14.1 Mechanical Cleaning

What is used to clean can be simple brushes or such special devices as pigging systems, which are propelled through the pipes mechanically, with compressed air, or water. Special pigs for GRP pipes are available on the market, which should be used. The cleaning effect is usually achieved with the pig's size relative to the pipe inside diameter. Models range from brushes with plastic bristles to complex tools with integral spray nozzles for pipelines.

14.2 Cleaning by Flushing at Normal Pressure

The most economical method of cleaning pipes is flushing, which increases the shear stress, thus scouring and washing out deposited sediment. Flushing ports or hydrants can be used here to provide additional water.

14.3 Cleaning by High Pressure Water Jetting

When pressure cleaning pipelines with water, take due care to prevent the inner surface of the pipes from being damaged. Always use methods that do not damage the pipe wall mechanically. Take special care to choose the appropriate nozzle (Figure 60). Select the nozzles such, that there can be no sudden impact of the nozzle touching the pipe wall. HOBAS can help in this regard.

HOBAS Pipes generally meet the requirements of DIN 19523. All relevant recommendations for HOBAS Pipes are summarized below:

- Good cleaning results are achieved at a pressure of 60 – 100 bar at the nozzle.
- The size of the inserts in the nozzle should be minimum 2.4 mm (Figure 60).
- Minimum 6 inserts in the nozzles should be existent
- The nozzle weight should be less than 2.5 kg.
- The nozzle drag velocity shall be 10 – 20 m/min. Avoid stopping of the nozzle during the cleaning procedure.
- Ensure that the nozzle remains at least 30 mm (x) away from the pipe wall. Use guides or spacers to maintain the minimum distance, if necessary (Figure 61).
- Keep the angle of the water jet to the pipe wall as small as possible. The angle for cleaning the pipe should be smaller than 25° (Figure 61).

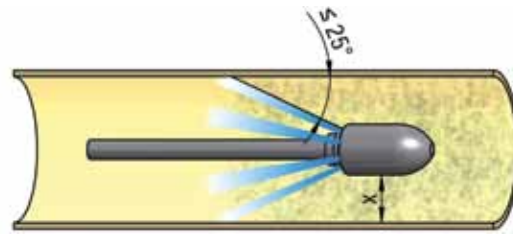

Fig. 61: Schematic drawing of cleaning with high pressure water jetting

To improve cleaning results, increase the amount of water used and not the pressure applied. Hence it is recommended to increase the size and the number of inserts in the nozzles.

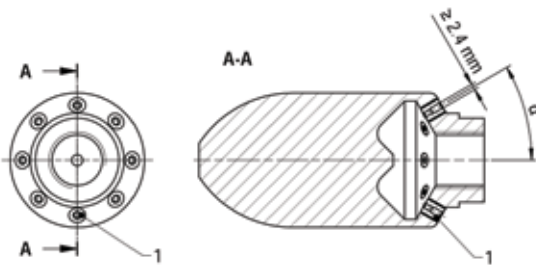

Fig. 60: Nozzle for high pressure cleaning

- 1 Insert for water jetting
- α Angle of water jet to pipe wall

15 List of Relevant Standards, Design & Calculation Basis

The standards and regulations below are purely informative and must be individually evaluated for every case and project.

15.1 International Standards, Design & Calculation Basis

Standards	
EN 1796	Plastics piping systems for water supply with or without pressure – Glassfiber reinforced thermosetting plastics (GRP) based on unsaturated polyester resin (UP)
EN 14364	Plastics piping systems for drainage and sewerage with or without pressure – Glassfiber reinforced thermosetting plastics (GRP) based on unsaturated polyester resin (UP) – Specifications for pipes, fittings and joints
ISO 10467	Plastics piping systems for pressure and non-pressure drainage and sewerage – Glassfiber reinforced plastics (GRP) systems based on unsaturated polyester (UP) resin
ISO 10639	Plastics piping systems for pressure and non-pressure water supply – Glassfiber reinforced thermosetting plastics (GRP) systems based on unsaturated polyester (UP) resin
ISO 25780	Plastics piping systems for pressure and non-pressure water supply, irrigation, drainage or sewerage – Glass-reinforced thermosetting plastics (GRP) systems based on unsaturated polyester (UP) resin – Pipes with flexible joints intended to be installed using jacking techniques
EN 15383	Plastics piping systems for drainage and sewerage. Glass-reinforced thermosetting plastics (GRP) based on polyester resin (UP). Manholes and inspection chambers
EN 805	Water supply – Requirements for systems and components outside buildings
EN 1610	Construction and testing of drains and sewers
ISO/TS 10465-1	Underground installation of flexible glass-reinforced pipes based on unsaturated polyester resin (GRP-UP) – Part 1: Installation procedures
EN 1092-1	Flanges and their joints – Circular flanges for pipes, valves, fittings and accessories, PN designated – Part 1: Steel flanges
EN 14396	Fixed ladders for manholes
EN 1990	Eurocode Basis of structural design
ISO 7005-3	Metallic flanges - Part 3: Copper alloy and composite flanges
EN 1091	Vacuum sewerage systems outside buildings
EN 752	Drain and sewer systems outside buildings
EN 1671	Pressure sewerage systems outside buildings
EN 476	General requirements for components used in drains and sewers
EN 934-2	Admixtures for concrete, mortar and grout. Concrete admixtures. Definitions, requirements, conformity, marking and labelling
UNE-EN 12889	Trenchless construction and testing of drains and sewers

Design and calculation basis	
SIA V190	Sewers; pipelines, standard and special structures
AWWA M45	Fiberglass Pipe Design, Third Edition
EN 1295-1	Structural design of buried pipelines under various conditions of loading. General requirements

15.2 Standards, Design & Calculation Basis Germany

Standards	
DIN 19523	Requirements and test methods for determination of the jetting resistance of components of drains and sewers
DIN 1072	Road and foot bridges, design loads
DIN 4124	Excavations and trenches – Slopes, planking and strutting breadths of working spaces

Design and calculation basis	
ATV-M 143, Part 6	Rehabilitation of drain and sewer systems outside buildings – Part 6: Leak testing of existing, earth covered sewers and drains and shafts using water, air overpressure and vacuum – Inspection, repair, rehabilitation and replacement of sewers and drains
ATV-DVWK-A 127	Static calculation of drains and sewers, third edition
DVGW GW 368	Longitudinal socket connections for pipes, fittings and valves made of ductile iron and steel
DVGW GW 310	Concrete thrust blocks; design criteria
DWA A 139	Construction and testing of drains and sewers
ZTVE-StB 97	Additional technical contract conditions and standards for earthwork in road construction

15.3 Standards, Design & Calculation Basis, the Netherlands

Standards	
NEN 3650-1	Requirements for Pipeline Systems - Part 1: General
NEN 3650-3	Requirements for Pipeline Systems - Part 3: Additional specifications for plastic pipelines
NEN 3651	Additional requirements for pipelines in or nearby important public works

Design and calculation basis	
NPR 3659	Underground pipelines – Basic principles for strength calculation
CUR 122	Underground pipelines - Structural design of unreinforced and reinforced concrete pipes
NPR 3218	Gravity Sewage - Installation and maintenance

15.4 Design & Calculation Basis, France

Standards	
NFT 57-105	Matieres plastiques renforcées au verre textile
NF P16-401	Piping. Internal cross-sections of ovoid sewer

Design and calculation basis	
Fascicule n°70	Cahier des clauses techniques générales - Ouvrages d'assainissement

Appendix

Instructions for Bolted Saddles

- 1 Decide the exact location of the connection and mark where the saddle is placed for drilling.
- 2 Cut the hole with a suitable core drill. The size of hole (-0/+5 mm) depends on the outside diameter of the pipe to be joined (Figure 62).
- 3 Place the saddle over the core hole and mark the holes to be drilled for the bolted connection.
- 4 After removing the saddle, drill two holes (Ø 13 mm) (Figure 63).
- 5 Insert the rubber gasket supplied on the underside of the saddle (knurled surface visible).
- 6 Place the saddle and join it to the pipe with the bolts and sleeves on them, inserting them from the inside to the outside. Tighten the bolts with washers (Figure 64).



Fig. 62: Core drilling



Fig. 63: Drilling two holes (diameter: 13 mm)

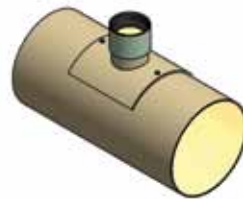

Fig. 64: Placing of the saddle and insertion of the bolting

Instructions for Glued Saddles

- 1 Decide the location of the connection, create space to work, remove any dirt from the pipe's outer surfaces, and ensure the surface to be glued is dry.
- 2 Determine the area to be cut out and glued, and mark with a felt pen.
- 3 Use a circular saw (with a carbide tipped or diamond blade, not a metal one) to cut along the marking or make a hole with a core drill, depending on the type of saddle, and check the dimensions (Figure 65).
- 4 Roughen and clean the surfaces to be glued. Apply the glue evenly to the surfaces. Seal the one component glue immediately after use to enable it to be reused.
- 5 Place and secure the saddle in position (e.g. with a strap) until the glue has completely cured (Figure 66).

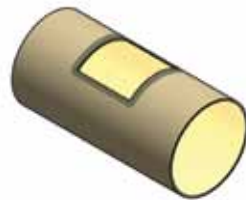

Fig. 65: Cutting or drilling

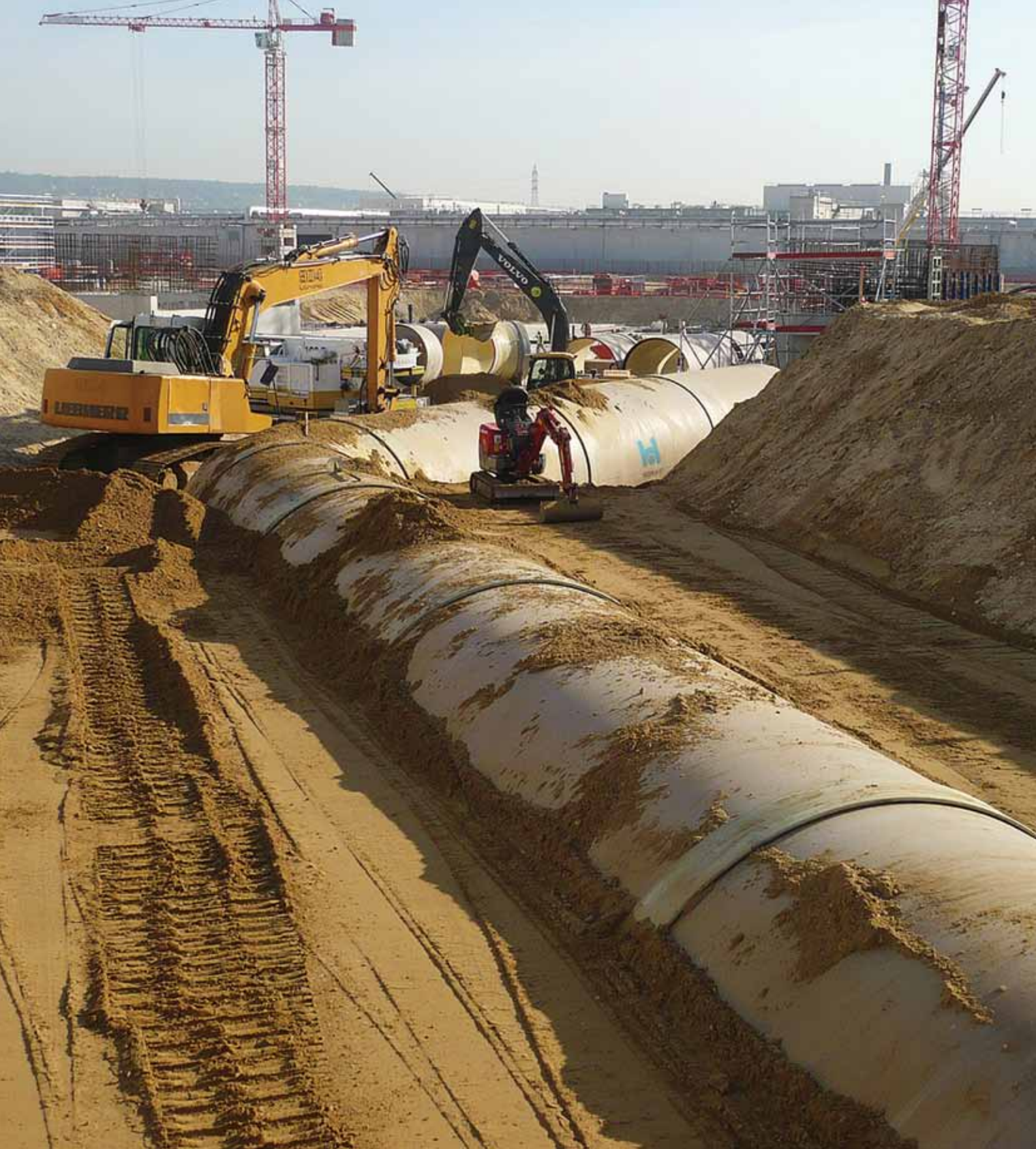

Fig. 66: Placing the saddle

A series of horizontal dotted lines spanning the width of the page, intended for handwritten notes or calculations.



A series of horizontal dotted lines spanning the width of the page, providing a guide for handwriting practice.



© Amiblu Holding GmbH

Publication: 09/2018

All rights reserved. No part of this document may be reproduced or utilized in any form or by any means without our prior written permission. All information in the document is correct at the time of going to press. However, we reserve the right to make changes without notice, in particular to technical data. The data given is not binding and must therefore be checked in each individual case and revised as appropriate.



The Hobas technology is owned and licensed worldwide by Amiblu.
Find more information and contact details at www.amiblu.com.

Amiblu Holding GmbH
Pischeldorfer Strasse 128
9020 Klagenfurt | Austria
T +43.463.48 24 24
info@amiblu.com | www.amiblu.com

Amiblu[®]