

Profile forms

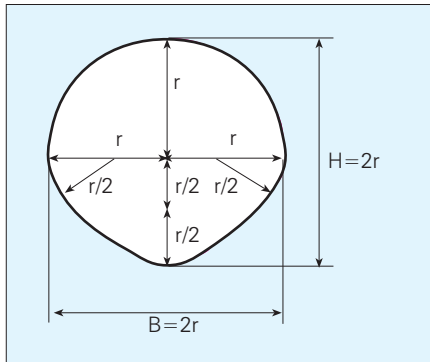

DN	Theoretical cross section mm	A sq m	L m
1,600	1,543	1.869	3.00
1,800	1,736	2.366	3.00

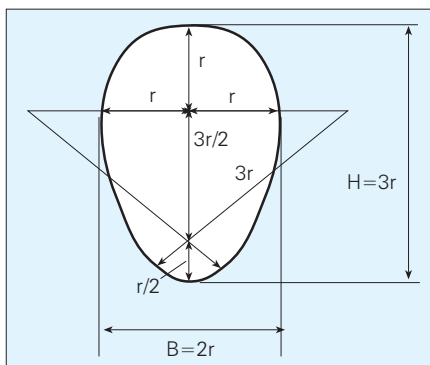

DN	Theoretical cross section mm	A sq m	L m
300/500	407	0.130	2.50
400/600	506	0.184	2.50
500/750	632	0.287	2.50
600/900	758	0.414	2.50
680/1050	875	0.561	3.00
800/1200	1011	0.735	2.50
900/1350	1136	0.930	2.50
1000/1500	1262	1.148	2.50
1200/1800	1515	1.654	3.00
1406/1907	1666	2.178	3.00

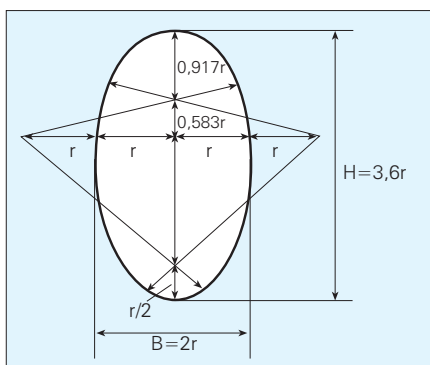

DN	Theoretical cross section mm	A sq m	L m
480/800	650	0.32	2.60
510/810	671	0.34	2.50
400/1000	753	0.43	2.00
750/1500	1182	1.08	2.50
1100/1400	1271	1.24	2.50
1080/1650	1376	1.42	2.50
1600/1800	1724	2.31	2.50

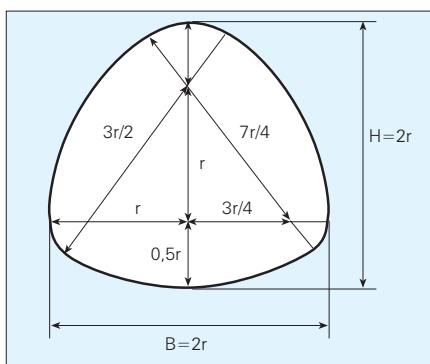

DN	Theoretical cross section mm	A sq m	L m
1360/1570	1469	1.596	2.00
2680/2590	2618	5.170	2.30

Other shapes available on request.

The information and recommendations herein reflect our knowledge at the time of publication. They do not however constitute a warranty of any kind, express or implied. Details should always be checked and adjusted for individual projects, if necessary. HOBAS Rohre GmbH reserves the right to change specifications without prior notice and assumes no responsibility for errors or omissions.